



RG7 7 KVA Military Generator



RG7 7KVA Military Generator

Generators are the systems which turn mechanical energy into electric energy and they provide continuous power requirements and energy needs of Armed Forces and law enforcement forces during battle with high efficiency at NATO standards. Generators are grouped according to their dimensions and types. AFSS can design, test and produce special sized generators between 2 kW and 1000 kW conforming to NATO Military standards. It produces super silent generators with 65 db sound level at 7 meters. Dual type generators which backup each other and also communicate, are other equipment of generator family. It creates solutions for the requirements of law enforcement forces as mobile and stable.

ADVANTAGES RG7 GENERATOR CONTAINS:

- The generator has the capability to get activated automatically in case the mains electricity coming to equipment shelter is cut.
- Military model AGM battery is used on RG7.
- Generator battery provides at least 40Ah capacity. (Battery has the capacity to activate the generator at least 3 times at -32°C ambient temperature using pre-heater.)
- RG7 has Diesel engine, F54, F34, F65 operate with fuel.
- Control board, has IP67 protection standard.
- Generator has the capability to operate at full-load for at least 8 (eight) hours by its own tank without any refuel.
- It enables 220 VAC/50 Hz single-phase output.
- The connectors on the generator are produced in accordance with MIL-DTL-38999 and/or VG95234 standards.
- 3 years of Guaranty.

GENERAL SPECIFICATIONS

| | |
|--|----------------------|
| Output Voltage | 220 VAC |
| Continuous Power | 5 kW |
| Output Power | 7 kW |
| Maximum Ampere | 20 A |
| Operating Temperature | -32 / +49 °C |
| Storage Temperature | -40 / +60 °C |
| Integrated Cooling System | Water Cooled |
| Sound Level | 75 dB @ 7m |
| Maximum Operating Elevation | 3000 m |
| Protection Level | IP23 |
| System Weight | 170 Kg ±5 |
| Connection Type | RS422 – TCP |
| Generator Fuel Consumption | 2,1 L/S |
| DIMENSIONS (Main Engine Unit) (LengthxWidthxHeight) | 922mm×538mm×701mm ±5 |

ENGINE SPECIFICATIONS

| | |
|---------------------|------------------------------|
| Engine | Kubota Z482 |
| Engine Type | Water Cooled Vertical Diesel |
| Intake System | Natural Intake |
| Cooling | Liquid Cooling |
| Output Power | 9,9 kW |
| Maximum Speed (rpm) | 3600 rpm |
| Starting | Electrical Starter |
| Fuel Type | Diesel |

ENVIRONMENTAL TESTS

| | |
|-------------------------------|--|
| Low Pressure (Operational) | Min. 3000 m |
| Solar Radiation | MIL-STD-810G, Method 505.5, Prosedüre I, Kategori A2 |
| Low Temperature (Operational) | MIL-STD-810G, Method 501.5, Procedure II, 49°C+ Solar Radiation |
| High Temperature (Storage) | MIL-STD-810G, Method 501.5, Procedure I, 60°C |
| Low Temperature (Operational) | MIL-STD-810G, Method 502.5, Procedure II, -32°C |
| Low Temperature (Storage) | MIL-STD-810G, Method 502.5, Procedure I, -40 °C |
| Humidity | MIL-STD-810G, Method 507.5, Procedure II, Figure 507.5-7 |
| Rain | MIL-STD-810G, Method 506.5, Procedure II |
| Vibration | To MIL-STD-810G, Method 514.6, Procedure I, Category 4, Table 514.6 C-VI, Figure 514.6 C-3 (3 axes) |
| Shock | MIL-STD810G, Method 516.6, Procedure I, Functional shock, 20 g 11 ms, Table 516.6-II, Sawtooth 3 axis. |
| Dust and Sand | MIL-STD-810G, Method 510.5, Procedure I, Procedure II |

EMI/RFI SPECIFICATIONS

| | |
|-------------------------|--|
| MIL-STD-461E/F Standard | CE102, RE102, CS101, CS114, CS115, CS116, RS103 Procedures |
|-------------------------|--|

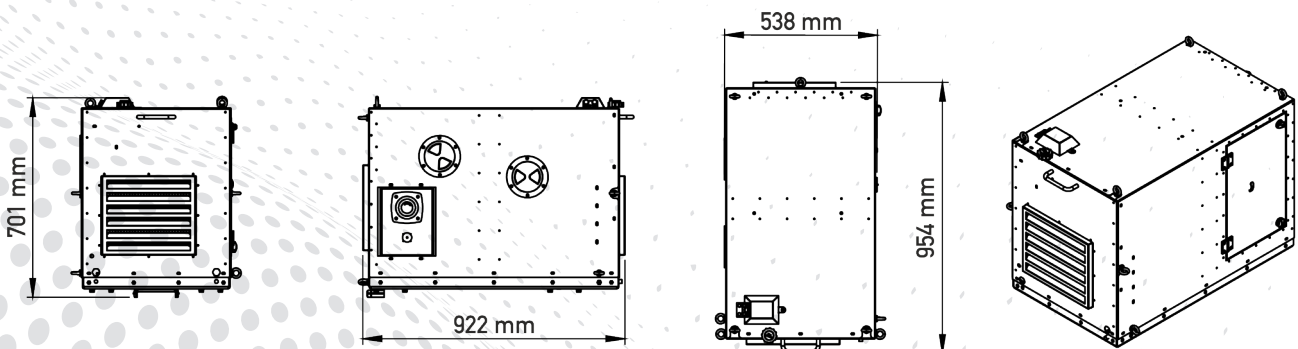

MF1005 GENERATOR CONTROL BOX



- It is positioned on the generator so that user can easily interfere in case of maintenance.
- It shows existing error and health status of the generator.
- It has 95% BIT capability.
- It is designed as per IP67 Standards. It also provides the opportunity to reach last 500 detailed log thanks to diagnostic.
- It enables to operate in 9-36 volts range.
- The signals transferred only with connectors, there is no need for panel.
- It is conformant to MIL-STD-810G and MIL-STD-461E/F standards.

| | | | | | |
|-----------------------------------|-------------------|--------|-------------|------------------------|------------------------------|
| Dimensions (Widthx-lengthxheight) | 140x213x160 ±5 mm | Weight | 3,1 kg ±0.1 | Communication Protocol | CANBUS J1939 - RS485 - RS422 |
|-----------------------------------|-------------------|--------|-------------|------------------------|------------------------------|

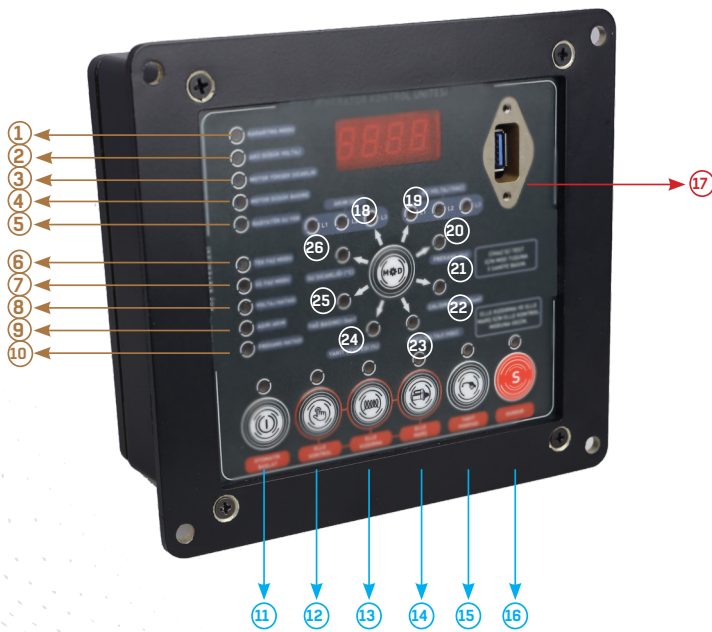

| | |
|-----------|-----------------|
| 17 | DIAGNOSTIC |
| 18 | AC CURRENT |
| 19 | AC VOLTAGE |
| 20 | FREQUENCY |
| 21 | 5 SECONT TO BIT |
| 22 | HOUR COUNTER |
| 23 | VOLTAGE |
| 24 | FUEL LEVEL |
| 25 | PRESSURE |
| 26 | TEMPRATURE |

| | | | |
|----------|---------------------|-----------|---------------------|
| 1 | BLACKOUT MODE | 9 | HIGH CURRENT LED |
| 2 | LOW VOLTAGE LED | 10 | FREQUENCY ERROR LED |
| 3 | HIGH TEMPRATURE LED | 11 | AUTOMATIC START |
| 4 | LOW PRESSURE LED | 12 | MANUEL START |
| 5 | WATER ALERT LED | 13 | GLOWING |
| 6 | SINGLE PHASE LED | 14 | START |
| 7 | THREE PHASE LED | 15 | FUEL PUMP |
| 8 | VOLTAGE ERROR LED | 16 | EMERGENCY STOP |