



RG5 5 KVA Military Generator



RG5 5KVA Military Generator

Generators are the systems which turn mechanical energy into electric energy and they provide continuous power requirements and energy needs of Armed Forces and law enforcement forces during battle with high efficiency at NATO standards. Generators are grouped according to their dimensions and types. AFSS can design, test and produce special sized generators between 2 kW and 1000 kW conforming to NATO Military standards. It produces super silent generators with 65 db sound level at 7 meters. Dual type generators which backup each other and also communicate, are other equipment of generator family. It creates solutions for the requirements of law enforcement forces as mobile and stable.

ADVANTAGES RG5 GENERATOR CONTAINS:

- The generator has the capability to get activated automatically in case the mains electricity coming to equipment shelter is cut.
- Military model AGM battery is used on RG5.
- Generator battery provides at least 40Ah capacity. (Battery has the capacity to activate the generator at least 3 times at -32°C ambient temperature using pre-heater.)
- RG5 has Diesel engine, F54, F34, F65 operate with fuel.
- Control board, has IP67 protection standard.
- Generator has the capability to operate at full-load for at least 8 (eight) hours by its own tank without any refuel.
- It enables 220 VAC/50 Hz single-phase output.
- The connectors on the generator are produced in accordance with MIL-DTL-38999 and/or VG95234 standards.
- 3 years of Guaranty.

GENERAL SPECIFICATIONS

Output Voltage	380/220 VAC
Continuous Power	4 kW
Output Power	7 kW
Maximum Ampere	17 A
Operating Temperature	-32 / +49 °C
Storage Temperature	-40 / +60 °C
Integrated Cooling System	Water Cooled
Sound Level	75 dB @ 7m
Maximum Operating Elevation	3000 m
Protection Level	IP23
System Weight	230 Kg +5
Connection Type	CANBUS/Seri/Ethernet
Generator Fuel Consumption	2,1 L/H
DIMENSIONS (Main Engine Unit) (LengthxWidthxHeight)	924mmx581mmx841mm ±5 ±5

ENGINE SPECIFICATIONS

Engine	Kubota Z482
Engine Type	Water Cooled Vertical Diesel
Intake System	Natural Intake
Cooling	Liquid Cooling
Output Power	9,9 kW
Maximum Speed (rpm)	3600 rpm
Starting	Electrical Starter
Fuel Type	Diesel

ENVIRONMENTAL TESTS

Low Pressure (Operational)	Min. 3000 m
Solar Radiation	MIL-STD-810G, Method 505.5, Procedure I, Category A2
Low Temperature (Operational)	MIL-STD-810G, Method 501.5, Procedure II, 49°C+ Solar Radiation
High Temperature (Storage)	MIL-STD-810G, Method 501.5, Procedure I, 60°C
Low Temperature (Operational)	MIL-STD-810G, Method 502.5, Procedure II, -32°C
Low Temperature (Storage)	MIL-STD-810G, Method 502.5, Procedure I, -40 °C
Humidity	MIL-STD-810G, Method 507.5, Procedure II, Figure 507.5-7
Rain	MIL-STD-810G, Method 506.5, Procedure II
Vibration	To MIL-STD-810G, Method 514.6, Procedure I, Category 4, Table 514.6 C-VI, Figure 514.6 C-3 (3 axes)
Shock	MIL-STD810G, Method 516.6, Procedure I, Functional shock, 20 g 11 ms, Table 516.6-II, Sawtooth 3 axis.
Dust and Sand	MIL-STD-810G, Method 510.5, Procedure I, Procedure II

EMI/RFI SPECIFICATIONS

MIL-STD-461E/F Standard	CE102, RE102, CS101, CS114, CS115, CS116, RS103 Procedures
-------------------------	--

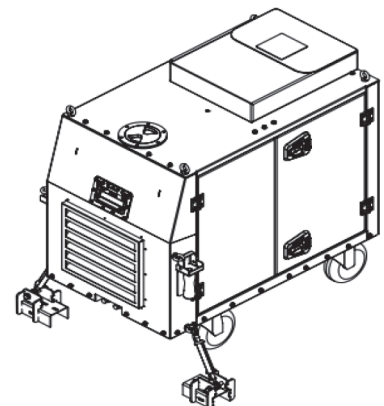
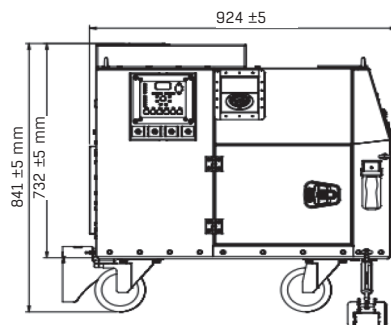
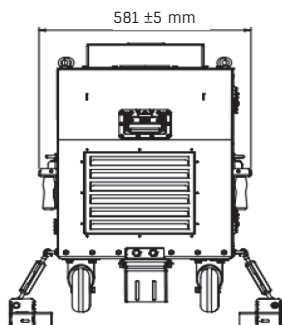

MF1005 GENERATOR CONTROL BOX



- It is positioned on the generator so that user can easily interfere in case of maintenance.
- It shows existing error and health status of the generator.
- It has 95% BIT capability.
- It is designed as per IP67 Standards. It also provides the opportunity to reach last 500 detailed log thanks to diagnostic.
- It enables to operate in 9-36 volts range.
- The signals transferred only with connectors, there is no need for panel.
- It is conformant to MIL-STD-810G and MIL-STD-461E/F standards.

Dimensions (Widthx-lengthxheight)	140x213x160 ±5 mm	Weight	3,1 kg ±0.1	Communication Protocol	CANBUS J1939 - RS485 - RS422
-----------------------------------	-------------------	--------	-------------	------------------------	------------------------------

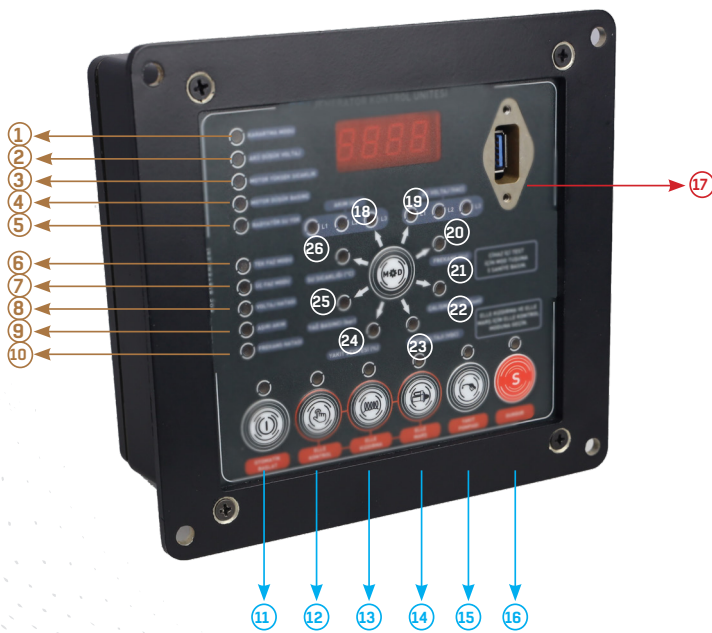

17	DIAGNOSTIC
18	AC CURRENT
19	AC VOLTAGE
20	FREQUENCY
21	5 SECONT TO BIT
22	HOUR COUNTER
23	VOLTAGE
24	FUEL LEVEL
25	PRESSURE
26	TEMPRATURE

1	BLACKOUT MODE	9	HIGH CURRENT LED
2	LOW VOLTAGE LED	10	FREQUENCY ERROR LED
3	HIGH TEMPRATURE LED	11	AUTOMATIC START
4	LOW PRESSURE LED	12	MANUEL START
5	WATER ALERT LED	13	GLOWING
6	SINGLE PHASE LED	14	START
7	THREE PHASE LED	15	FUEL PUMP
8	VOLTAGE ERROR LED	16	EMERGENCY STOP