



# NE-MAC1000 MILITARY AIR CONDITIONER



## MILITARY AIR CONDITIONER

Nowadays, the importance of air conditioners is increasing day by day. Particularly in indoor areas, the part air conditioners play in preventing damage and malfunction caused by overheating is increasing day by day.

NE-MAC1000 is an air conditioning unit specially designed for military containers and shelters to cool the personnel area and equipment. With the trap door system, the air conditioner is mounted inside the container, hung on the rails in the cover system and pushed out of the container during use. During transport or when not in use, the unit can be pushed back into the container and the lid can be locked.

The operating mechanism of the NE-MAC1000 is based on a cooling circuit and two powerful fans. In the front, there is the evaporator and the evaporator fan which draws the hot air in the environment. The evaporator section draws the evaporator and the warm interior air of the container through the cold evaporator and blows the cooled air out through the discharge grille. The condenser coil which is in the rear of the unit, returns heat from the condenser fan and indoor air to the surrounding atmosphere. In a special version, this unit is equipped with an optional electric heating element to heat the indoor air during cold start or cold environment.

## GENERAL SPECIFICATIONS

<ul style="list-style-type: none"><li>• It is placed in a cabinet made of 0.8 mm galvanized and sheet steel.</li></ul>	<ul style="list-style-type: none"><li>• Two speed selectors for the internal fan.</li></ul>
<ul style="list-style-type: none"><li>• Top surface paint is standard NATO green, RAL 6014.</li></ul>	<ul style="list-style-type: none"><li>• "VENTILATION ONLY" option that allows ventilation without cooling.</li></ul>
<ul style="list-style-type: none"><li>• Can provide cooling at ambient temperatures up to +60°C</li></ul>	<ul style="list-style-type: none"><li>• Fresh air intake.</li></ul>
<ul style="list-style-type: none"><li>• Scroll compressor for high reliability and low noise level.</li></ul>	<ul style="list-style-type: none"><li>• Coarse filters in front of the outside air intake and the fresh air intake as well as the indoor air intake.</li></ul>
<ul style="list-style-type: none"><li>• Environmentally friendly R134a refrigerant.</li></ul>	<ul style="list-style-type: none"><li>• Easy mounting to the cover system with four lifting arms, one at each corner of the unit, or a special lifting system (accessory).</li></ul>
<ul style="list-style-type: none"><li>• 2 kW electric heating element (special version)</li></ul>	<ul style="list-style-type: none"><li>• The trap door (accessory) acts as protection against rain and excessive sun while the unit is running.</li></ul>
<ul style="list-style-type: none"><li>• It is easily controlled with the room thermostat placed in the container.</li></ul>	<ul style="list-style-type: none"><li>• It is stored in the container during transportation.</li></ul>

## TECHNICAL SPECIFICATIONS

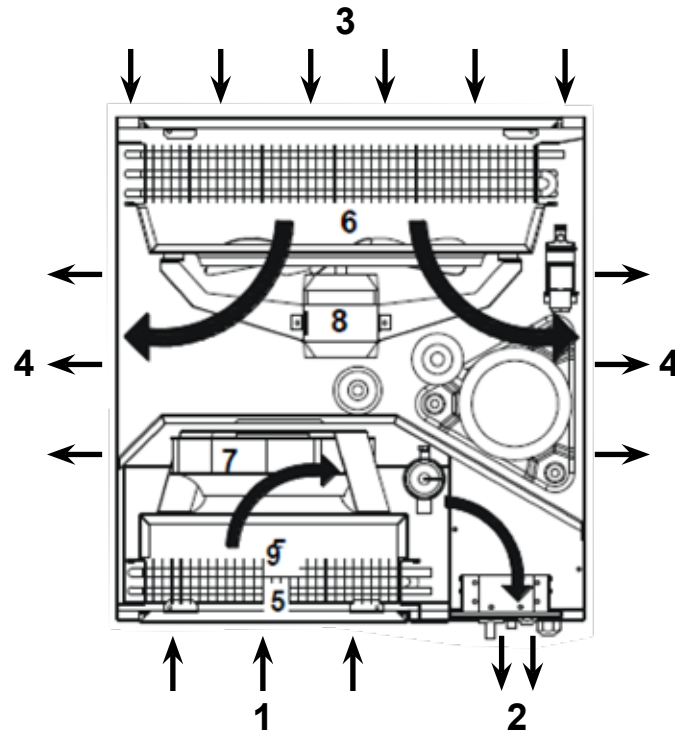

1	Recirculating air inlet	6	Concentrator
2	Discharging the refrigerated air in the container	7	Centrifugal fan
3	Condenser air inlet	8	Axial fans
4	Condenser air outlet	9	Heaters (optional) 1 Recirculating air inlet
5	Evaporators		

### MILITARY STANDARDS

MIL-STD 810G

MIL-STD 461F

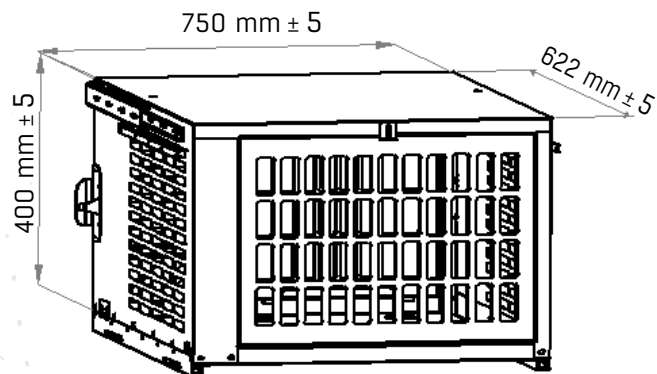

## TECHNICAL SPECIFICATIONS

	DRY ENVIRONMENT		HUMID ENVIRONMENT	
Environmental Conditions	45 °C 20 % RH		60 °C 20 % RH	
Airflow	420 m <sup>3</sup> /h	700 m <sup>3</sup> /h	420 m <sup>3</sup> /h	700 m <sup>3</sup> /h
Cooling without changing moisture content	3.0 kW	4.6 kW	1.2 kW	2.0 kW
Cooling with changing moisture content	0.3 kW	0.1 kW	2.5 kW	2.9 kW
Total cooling	3.3 kW	4.7 kW	3.7 kW	4.9 kW

Feature	Value
Voltage/PH/ Frequency 230 V 1 PH / 50 Hz	230 V 1 PH / 50 Hz
Maximum Electricity Consumption 2.3 kW / 9.8 A	2,3 kW / 9.8 A
Cooling Capacity (max.) 4.9 kW	4,9 kW
Heating capacity (optional) 2.0 kW / 8.6 A	2.0 kW / 8.6 A
Air flow low evaporator 420 m <sup>3</sup> / h	420 m <sup>3</sup> / h
High air flow evaporator 700 m <sup>3</sup> / h	700 m <sup>3</sup> / h
Airflow capacitor 1400 m <sup>3</sup> / h	1400 m <sup>3</sup> / h
Refrigerant/Charge R134 / 1.4 kg	R134 / 1,4 kg
Maximum Refrigerant Pressure 28 Bar	28 Bar
Operating Temperature 20-60 °C	20-60 °C
Weight 80 kg	80 kg
Noise level (1m) low speed 56 / 46 dB (A)	56 / 46 dB (A)
Noise level (1m) high speed 62 / 60 dB (A)	62 / 60 dB (A)
Global Warming Potential	1430