





Proudly Made in USA



## FIRE EXTINGUISHER SYSTEMS



Page-6  
FS-1 GASAGENT  
EXTINGUISHER



Page-12  
ARESFSII+ CONTROL  
UNIT



Page-15  
UV-IROPTICAL  
DETECTOR

## CBRN SYSTEMS



Page-24  
AIR  
MEASURING DEVICE



Page-32  
CV-90 COMPATIBLE  
GASFILTER



Page-38  
AR-MF 60 MASKED TYPE  
CBRN FILTRATION

## MILITARY POWER SYSTEMS



Page-60  
MILITARY GENERATOR  
28 KVA -RG28



Page-61  
AR-250 GENERATOR  
CONTROL UNIT



Page-64  
APU - A0606T

## LASER WARNING SYSTEMS



Page-42  
LW4000 LASER  
WARNING SYSTEM



Page-44  
LW2000 LASER  
WARNING SYSTEM



Page-46  
TACTICAL WEARABLE  
LASER WARNING SYSTEM  
TWL-200

## SMOKE GRENADE SYSTEMS



Page-50  
SLX GRENADE  
LAUNCHER



Page- 52  
15 BARRELS AUTOMATIC  
GRENADE LAUNCHER



Page-54  
TRILAUNCHER



Page-55  
SELF PROTECTION POD



Page-57  
CCU-6  
CONTROL UNIT

# AUTOMATIC FIRE EXTINGUISHING SYSTEMS

The most dangerous threats during land operations are ATGM and RPG attacks. These weapons can destroy a heavy armored vehicle within seconds. Fire suppression systems developed by AFSS; could suppress the explosion caused by unguided antitank attacks, mine explosions, inflammable and caustic hazardous materials, liquid fuel fires, RPGs (RPG 6, RPG 7, etc.), antitank missiles (ATM) or any other heavy armor-piercing ammunition. UV-IR optical sensors have the capability of detection in less than 3 milliseconds, control units activate within 6 milliseconds after detection and extinguishing cylinders become active in less than 7 milliseconds. By means of AFSS fire suppression systems, fire is suppressed in less than 250 milliseconds. This system meets all the conditions described in NATO's STANAG 4317 standard and all qualification tests are conducted at NATO Level 4 standard together with customer. By means of AFSS body and tire fire extinguishing systems, the fires caused by Molotov cocktails can easily be extinguished even while the vehicle is under threat. The system in general protects human life and precious property against destruction which can be caused by armor-piercing ammunition or hydrocarbon fuel in the vehicle.

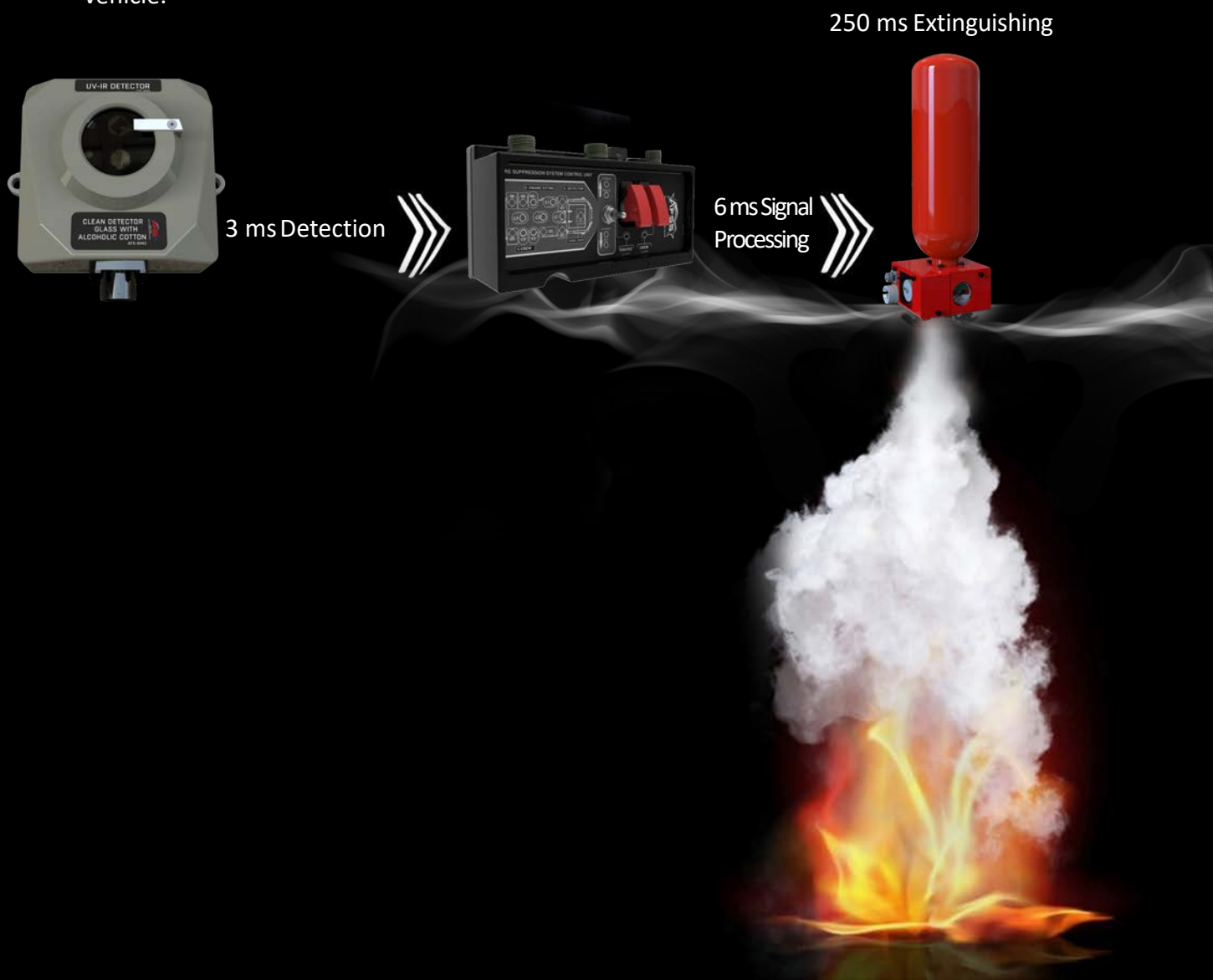

## ENGINE FIRE EXTINGUISHING SYSTEM



## VEHICLE BODY EXTINGUISHING SYSTEM



















# FS-1 GAS AGENT EXTINGUISHER WITH HOSE

> While designing armored vehicles, the most important thing is to use the volume within the vehicle correctly and effectively. Since the extinguishing agent is dispensed directly from the cylinder in AFSS's existing FS-1 fire suppression cylinders, it is significant to locate it effectively within the vehicle. During tank modernization or small armored vehicle projects, problems have been encountered in locating the cylinders within the vehicle. AFSS could provide a fire suppression system feature within the same duration as per NATO STANAG 4317 by utilizing the FS-1 extinguisher cylinder with hose they developed to address these problems. Additionally, the hose line could be extended up to 2 meters by increasing the pressure on the cylinder. This way, vehicle designs could be easily integrated with the FS-1 cylinder with hose by the AFSS team, and its qualification could be completed more quickly.



## TECHNICAL SPECIFICATIONS

 High speed reaction in a time period less than 6 ms	 Cylinder capacity: different sizes between 3 - 10 kg
 Pressure indicator	 Super pressurisation: Drynitrogen
 360° homogenous distribution	 Cylinder nominal pressure: 60Bar
 Harmless to human life	 Operating temperature: -55 +70C°
 Refillable by refillkit	 Weight : 5 ±0,5 kg 18±0,5 kg
 MTBF duration of 250,000hours	 Pyrotechnic activation
 Extinguisher active substance: HFC 227 ea	 MIL-STD-810H, MIL-STD-461G, MIL-STD-1275E certifications
 Substance helping respiration: Sodium bicarbonate	 Conforming to UL, CE GOST-R standards





*Electrically  
Activated  
FAERO*

*Mechanically  
Activated  
FAERO-MA*

*FAERO-MEA with  
Mechanical  
and Electrical  
Activation*

# FAERO

## AEROSOL FIRE EXTINGUISHERS

FAERO Aerosol Fire Extinguisher family is designed to extinguish and neutralize type A (solid fuel), B (liquid fuel), C (gas fuel) and type E (electrical) fires in closed volumes.

After calculating the required extinguishing agent concentration for each type of fire and the volume that needs to be protected, and determining the appropriate FAERO extinguisher for the volume, the solid NRECM agent in the FAERO cylinder and the total number of FAERO cylinders in the protected area are determined.

FAERO Aerosol Extinguishers offer solutions for every need with electrical, mechanical and both electrical and mechanical activation options.

**Electrically Activated FAERO:** FAERO Electrically Activated Aerosol Fire Extinguisher communicates with the control box through the military connector on it and is activated by the fire signal sent to the control box by the UVIR / Thermal Fire Detection Detectors produced by AFSS Industry. It can also be remotely controlled by providing manual activation when necessary.

**Mechanically Activated FAERO:** FAERO-MA Mechanically Activated Aerosol Fire Extinguisher; It offers an independent system solution that does not require electricity, where fire detection and extinguishing are combined mechanically. Thanks to the thermal sensor/activator on it, it can detect fire at various optional temperatures (57°, 68°, 79°, 93°C, 141°C, 180°C) according to different requirements, without any control box it can be activated mechanically without the need for an electrical power.

**FAERO with Mechanical and Electrical Activation:** FAERO-MEA Mechanical and Electrical Activated Aerosol Fire Extinguisher is a combined version of Mechanically Activated FAERO-MEA and Electrically Activated FA-ERO. Thanks to the thermal sensor/activator on it, it can perform automatic detection-extinguishing. At the same time, it can be connected to the control box and be activated remotely thanks to the military connector on it.



## GENERAL SPECIFICATIONS

SPECIFICATIONS									
PRODUCT	FAERO			FAERO-MA			FAERO-MEA		
Agent Amount((g)	125	250	500	125	250	500	125	250	500
ACTIVATION METHOD	Electrical			Manual - Mechanical			Electrical - Manual - Mechanical		
DISCHARGING TIME	4-6 seconds								
DISCHARGING DISTANCE	2 m								
ACTIVATION	1.2 A - 24V DC			Pin assist - Determined Temp.			1.2A - 24V DC** - Pinassist - Determined Temp.		
OPERATING TEMPERATURE	-40°C (-104°F) - 120°C (248°F)								
POWER REQUIREMENTS	1.2A @ 3 millisecond			*			1.2A @ 3 millisecond**		
DIMENSIONS(mm) S	Ø88 H 132	Ø88 H202	Ø88 H295	Ø88 H209	Ø88 H251	Ø88 H345	Ø88 H209	Ø88 H251	Ø88 H345
WEIGHT (g) ± 10	1500	2200	3100	1510	2210	3110	1570	2300	3240
CYLINDER VOLUME(m³)	1.25	2.5	5	1.25	2.5	5	1.25	2.5	5
DETECTING OPTIONS	*			57°C - 68°C - 79°C - 93°C - 141°C - 180°C			57°C - 68°C - 79°C - 93°C - 141°C - 180°C		
PROTECTION LEVEL	IP67(optional)			IP67(optional)			IP67(optional)		
TECHNICAL DRAWING	<p style="text-align: center;">1</p>			<p style="text-align: center;">2</p> <p style="text-align: center;">1</p>			<p style="text-align: center;">2</p> <p style="text-align: center;">1</p> <p style="text-align: center;">3</p>		
	1-Electrical activation and manual activation with control box			1-Pinassist 2- Temperature automatic activation			1-Pinassist 2- Temperature automatic activation 3- Electrical activation and manual activation with control box		



# FORA LIQUID AGENT EXTINGUISHER

(BODY - TYRES – FUEL TANK)

➤ FORA protects exterior body and tyres of armored vehicles and combat vehicles against external factors thanks to the liquid agents within 10L of extinguishing cylinders. This extinguishing liquid is a special liquid developed by AFSS. The liquid agents which used here are carried to requested area by the help of hoses and nozzles. 1 FORA extinguishing cylinder and 8 nozzles for body section, one FORA extinguishing cylinder and 4 nozzles for both tires are used. When this system is activated, it extinguishes within 10 seconds, then it prevents any new fire from outbreaking for 3 minutes.

## TECHNICAL SPECIFICATIONS

High speed reaction in a time period less than 10 milliseconds	Cylinder capacity: Different sizes between 8 - 10 litres
Pressure indicator	Super pressurisation: Dry nitrogen
Solenoid activation	Cylinder nominal pressure: 45 - 100 Bar
Harmless to human life	Operating temperature : -32 / +71 C°
Refillable by refill kit	Weight : 24-30 kg for 8-10 lt capacity
MTBF duration of 250,000 hours	MIL-STD-810H, MIL-STD-461G, MIL-STD-1275E certifications
Extinguisher active substance: Liquid AFFF (Biological)	Conforming to UL, CE GOST-R standards
IP67 water and dust ingress protection	Vertical and horizontal locating option

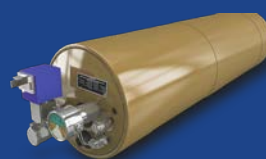
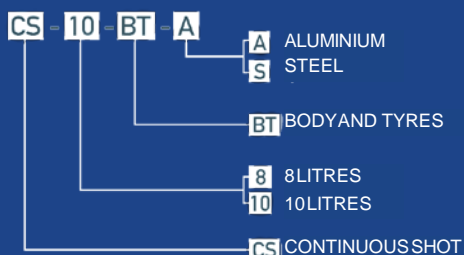

Optional CARC Colours (Chemical resistant coating)

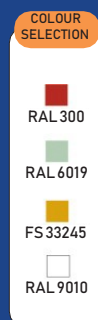

## CREW FIRE EXTINGUISHING SYSTEM



## VEHICLE BODY EXTINGUISHING SYSTEM





- > ARESFSS control unit is the unit section where warning, detection and fault status of the system which is designed and developed by ARESFSS Industry completely as a completely domestic product, by power leds belonging to each cylinder and detector. ARESFSS Control unit which operates flexibly, complying with system configurations and operating logic, controls fire extinguishing and fire suppression system. This smart control unit which has a many chambered compact structure, receives the detection signals for power group, body, tire, engine, crew and other compartments to be protected and activates the system.
- > By means of smart control unit, system verifications and logical operations could be performed. It has features of built-in-test, manual activation and automatic activation. It has water and dust protection at IP 67 level. Error, alarm and other data regarding fire suppression and fire extinguishing system are transmitted to vehicle main computer by CANBUS communication infrastructure.

# ARESFSS

## III+

 Compartment Activation  
(Button Light Green)

 Compartment Alarm  
(Button Light Red)

Manuel Body Activation  
Manuel Tires Activation  
Manuel Engine Activation  
Manuel Crew Activation  
Blackout Mode  
Built In Test  
Combat / Peace Mode Selection





# ARESFSS II+ CONTROL UNIT





















- > Ares control unit is the unit section where warning, detection and fault status of the system which is designed and developed by AFSS completely as a completely domestic product, by power leds belonging to each cylinder and detector. Ares Control unit which operates flexibly, complying with system configurations and operating logic, controls fire extinguishing and fire suppression system. This smart control unit which has a many-chambered compact structure, receives the detection signals for power group, body, tire, engine, crew and other compartments to be protected and activates the system.
- > By means of smart control unit, system verifications and logical operations could be performed. It has features of built-in-test, manual activation and automatic activation. It has water and dust protection at IP 67 level. Error, alarm and other data regarding fire suppression and fire extinguishing system are transmitted to vehicle main computer by CANBUS communication infrastructure.

# ARESFSS

# II+



## TECHNICAL SPECIFICATIONS

 High speed reaction in a time period less than 6 milliseconds	 MTBF duration of 140,000hours
 Automatic and manual built-intest opportunity(BIT)	 Galvanically isolated
 Accepts input signals from optical detectors, thermocouples and thermal wire	 Power supply: 24VDC nominal (16-32V)
 Automatic-manual activation	 Power consumption: 450 mA @ 24 VDC
 Manual activation and output signal for each compartment	 Weight : 2240 gr ± 290 gr (Depends on configuration)
 Fault indication for each cylinder and detector on vehicle diagram	 Dimensions (WXLXH) :180 x 86 x 149 mm (±5 mm)
 Alarm LEDs forevery compartment	 Produced as per PCB IPC A-610 class-3
 Alarm logging until next reset	 IP67 water and dust ingressprotection
 Recording fire detections, manual activations and error conditions	 Salt fog test resistance 800 hours
 The last 500 datalog entries can be reached	 MIL-STD-810H ,MIL-STD-461G, MIL-STD certifications, 1275E UL, conforming to CE GOST-R standard

## UNIT CONTROL CAPABILITIES

12 Detector ( Programmable Function)
12 Cylinders( Crew(4)Engine (2)Tires (2) Body(4))
Double Shot Feature( Crew and Engine )
While manual buttons provide activation, data could be recorded by CANBUS independant from electronicsystem.
DC/DCIsolation

Manual Body Activation
Manual Tires Activation
Manual Engine Activation
Manual Crew Activation
Blackout Mode
Built In Test Equipment (BIT)
Combat / Peace Mode Selection

### 4 Inputs:

- Input 1 : Vehicle ignition switch ( 'NO' contact, switching to battery (+))
- Input 2 : Blackout input ( 'NO' contact, switching to battery (-))
- Input 3 : Emergency input ( 'NO' contact, switching to battery (-))
- Input 4 : Configurable digital inputs ( 'NO' contact, switching to battery (-))

### 4 Output (1A 24VDC):

- Output 1 : Main warning ( 1A @24VDC)
- Output 2 : Crew fire alarm ( 1A @24VDC)
- Output 3 : Engine fire alarm ( 1A @24VDC)
- Output 4 : Crew fan controller ( 1A @24VDC)

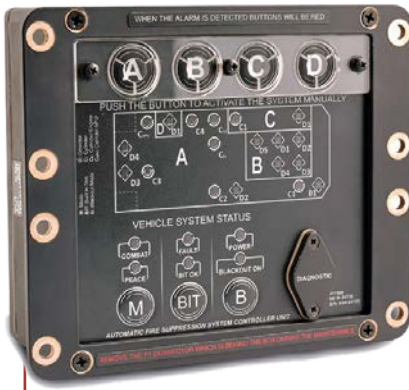

# ARESFSS IV CONTROLLER UNIT

Manual Body Activation
Manual Tires Activation
Manual Engine Activation
Manual Crew Activation
Blackout Mode
Built In Test Equipment (BIT)
Combat / Peace Mode Selection
Log Recording Feature



# ARESFSS III CONTROLLER UNIT

Manual Body Activation
Manual Tires Activation
Manual Engine Activation
Manual Crew Activation
Blackout Mode
Built In Test Equipment (BIT)
Combat / Peace Mode Selection

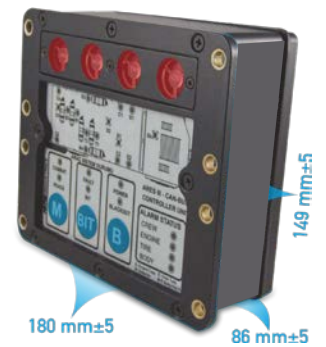

# ARESFSS SLX CONTROLLER UNIT

Manual Engine Activation
Manual Crew Activation
Combat / Peace Mode Selection
Built In Test Equipment (BIT)

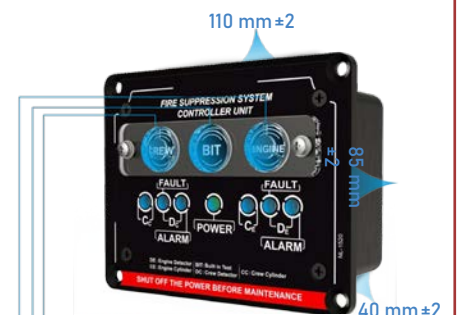

**Manual Activation Button**  
Cylinders Could Be Manually Activated  
**BIT Button** Built In Test could be performed  
**Manual Activation Button**  
Cylinders Could Be Manually Activated  
Tüpler Manuel Olarak Aktive Edilebilir





# UV-IR OPTICAL DETECTOR

- > Optical detectors detect the fire ball created by the ammunition penetrating into the armor within 3 milliseconds, before it reaches to the pressure and heat level that can harm its surrounding, and send an alarm signal to control box on vehicles which are hit by RPG or ATGM rockets. It detects heat and light waves at different frequencies by UV and IR sensors within it, makes required matches and send flame signal to control box. Detectors are genuinely designed by AFSS engineers according to NATO Stanag 4317 and American MIL PRF 62546C standards. UVIR flame detectors have also successfully passed high temperature, low temperature, humidity, shock-vibration, corrosion and EMI/EMC tests as per MIL-STD-810H and MIL-STD-461F standards.
- > Detectors have been specially designed as IP67 and can stay under 1 meters of water for half an hour. The detectors also having protection for false alarms, do not react against false alarms such as sunlight, vehicle headlights, welding beam, infrared heater, cigarette ash. Along with these systems protecting the engine and the crew on military armored vehicles, electric vehicles, buses, planes, jet planes and ships; total 40 thousand detector accomplish their duty in the field.

Highspeed reaction in a time period less than 3 ms	Immunity to false alarm as per MIL-PRF 62546C
UV/IR dual sensor - Thermal Sensor	Power supply : 24 VDC nominal (16-32V) Power consumption : 70 mA @ 24 VDC
180 C° fire detection thermal sensor	Advanced software algorithm
140° blind spot detection	Operating temperature : -51 / +120 °C
Sensitivity against creeping fire	Weight : 480 g ± 50g
MTBF duration of 150,000 hours	MIL-STD-810H, MIL-STD-461F, MILSTD-1275E certifications
Production as per PCB IPCA-610 class-3	Conforming to UL, CE GOST-R standards
IP67 water and dust ingress protection Salt fog resistance: 800 hours	10 years of shelf life
Dimensions (WXLXH): 85 x 49 x 100 mm(±5 mm)	Storage temperature : -55 °C +150 °C

# TRIPLE IR OPTICAL DETECTOR



## FALSE ALARM CHART

Test Performed	Spec Requirements
Headlight (55-65 W)	15 cm
Incandescent Lamp (100 W)	2,5 cm
Halogen Lamp (500 W)	5 cm
Fluorescent Light (40 W)	At any distance
UV Lamp (75 W)	At any distance
In-Vehicle Lighting (5 W)	At any distance
Match	20 cm
Sodium Lamp (70-250 W)	At any distance
Xenon Lamp (30 W)	5 cm
Flashlight (1 W)	At any distance

### COLOUR SELECTION

- RAL 300
- RAL 6019
- FS 33245
- RAL 9010

12,5x12,5 cm Fire from 90 cm

30x30 cm Fire from 250 cm

50x50 cm Fire from 270 cm

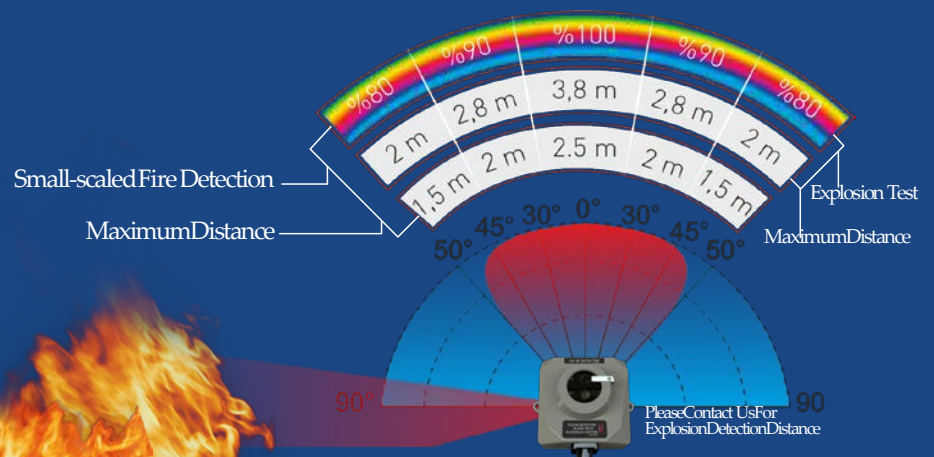

# CONTINUOUS HEAT SENSOR

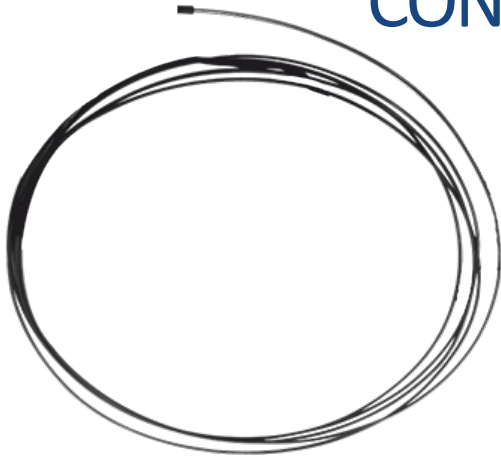

## TECHNICAL SPECIFICATIONS

Self-repairing (it can turn back to normal after it reaches 870°C temperature)

- K-Type TC components
- Resistant to chemical actions
- It has grounding specification
- It can still detect even after the wire is cut into pieces
- Storage temperature: -55°C +800°C
- Flexibility: Elasticity feature
- Thickness: 6 mm
- Coating material: Inconel coating
- Measurement type: K type thermocouple

Continuous sensor thermal wires are used for detecting the fire in the areas they are located in cases of fire. In this system, it is aimed to detect fire by fastening the continuous thermal wire on surfaces in the area desired to be protected from fire. As for detection period, detection can be performed within 5 up to 20 seconds depending on magnitude, class of fire and the area it bursts out.

As for detection temperature it can make detection between 50 and 250 degrees according to customer's desire. It can transmit detection temperature to control box and the ambient temperature can also be measured. It is suitable for the multi structured complicated systems which are not suitable for UV-IR detectors to make detection. It is multi-usable and can continue detection after each activation. It has an operation temperature between -55°C and +250°C and it is extensively used on tank engines, electrical panels and generators.

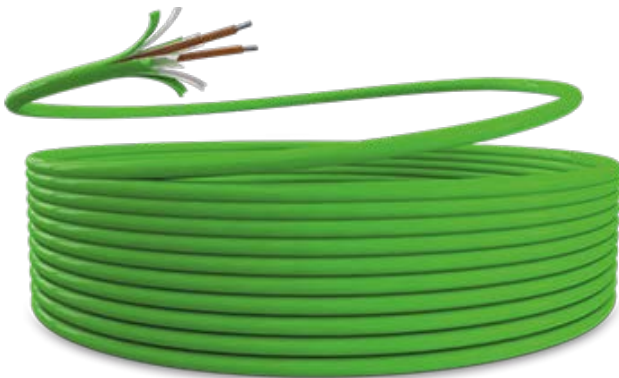

# LINEAR SENSOR WIRE

## TECHNICAL SPECIFICATIONS

- Disposable
- With wide detection area
- Wire gauge: 6 mm
- Bending radius: 150 mm
- Operation temperature: -55 °C + 170 °C
- Storage temperature: -55 ° C+ 170 °C
- MTBF period 200,000 hours
- Design length range between 1 meter and 15 meters
- Pre-set alarm levels: 120 -150 -170° C

Linear sensor thermal wires are used for detecting the fire in the areas they are located in cases of fire. In this system, it is aimed to detect fire by fastening the thermal wire on surfaces in the area desired to be protected from fire. As for detection period, detection can be performed within 10 up to 40 seconds depending on magnitude, class of fire and the area it bursts out. When the ambient temperature reaches to 180 °C, the structure of the wire starts to get damaged and the outer layer melts and the wires inside touch each other and conduct fire alarm to control box.

It is suitable for the multistructured complicated systems which are not suitable for UV-IR detectors to make detection. It is disposable and should be changed after each activation. It has an operation temperature between -55°C and +170°C. In general, it is extensively used on vehicle engines, electrical panels and generators.



## DEFLECTOR

- The deflector is the main part that provides 360° distribution of the extinguishing agent inside the vehicle.
- After the activation of the cylinders, the active substance is dispersed quickly and effectively with the help of deflectors.
- According to the position of the tubes in the vehicle, the dispersion direction can be adjusted up and down.
- Weight: 390g ± 50g

## Nozzle

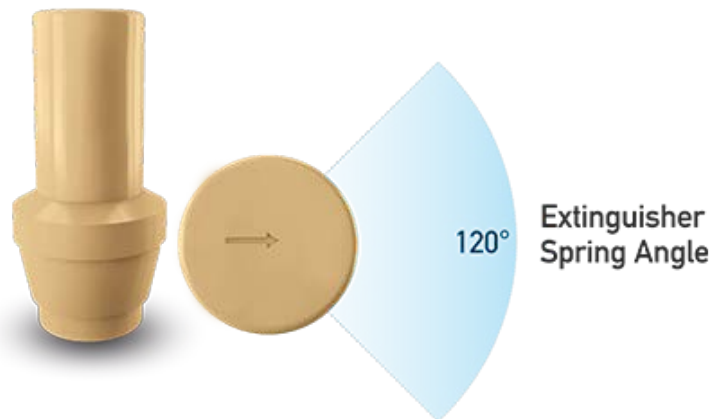

- The viewing angle is between 90 and 180 degrees.
- Inner diameter is 5 millimeters.
- Dispersion rate is 50 - 60 liters/minute
- Easy direction adjustment with the symbol arrow on the front.
- It is corrosion resistant
- The material type is 304 stainless or brass.
- Weight: 20 g ± 5

Nozzle Code	Nozzle Name	Orifis (mm)	Extinguisher Spring Angle
NE-P-44706	A51	5	90°
NE-P-44707	A52	5	120°
NE-P-44708	A53	5	150°
NE-P-44709	A54	5	180°
NE-P-44710	A61	6	90°
NE-P-44711	A62	6	120°
NE-P-44712	A63	6	150°
NE-P-44713	A64	6	180°
NE-M-21422	ENGINE NOZZLE ALU	3/8 INC (9.525 mm)	FULL CONE 120°
NE-M-21315	TIRES NOZZLE ALU	3/8 INC (9.525 mm)	FULL CONE 120°

# At the Peak of Time

Integration into more than 25,000 Vehicles



Fire is suppressed  
in totally less  
than 250 ms

3 ms  
Detection

**FIRE SUPPRESSION SYSTEM**



# CBRN DETECTION AND FILTRATION SYSTEMS

CBRN Filtration Systems has the function of filtrating war and toxic gas agents so as to ensure healthy respiration of the crew against Chemical, Biological, Nuclear and Radioactive threats which are today's warmethods.

CBRN Filtration Systems has 3 different usage options. These are CBRN Filtration Systems with Over Pressure, Masked Type CBRN Filtration Systems and Positive Pressure and Independent Masked CBRN Filtration Systems. These systems are used in civilian and military fields. CBRN systems are designed and qualified as per Nato AEP 54 standards.

CBRN Filtration Systems have 3 main structures. These are Control Units, CBRN Filters and CBRN Cabin. CBRN Filtration systems have successfully passed high temperature, low temperature, high humidity, shock-vibration and EMI/EMC tests as per MIL STD 810 and MIL STD 461 standards. Besides, CBRN systems produced by AFSS has the capability to be mechanically integrated to air conditioning system of the vehicle.

CBRN Filtration systems which heats the air by the heaters it includes, can provide conditioned air to the user according to present conditions and circumstances by integrating into vehicle air-conditioner for cooling the air. CBRN Filtration Systems produced by AFSS are used on military, civilian vehicles, safety facilities, command shelters at ships and planes and armoured vehicles of the armies of total 29 countries.



# FULL-SCOPE CBRN DETECTION, MEASUREMENT, ANALYSIS AND PREVENTION SYSTEM SOLUTIONS



- Detection at High Precision

- Capability to Detect Different Biological, Chemical Agents

- Automatic – Semi Automatic Operation System

- LCD Display Support



# BIOLOGICAL DETECTION SYSTEM

Biological Threat is a particular source of concern as especially most of the Biological agents are easy to be produced, carried and spread. Most of the diseases caused by Biological agents are quite contagious and in the meantime infected people continue to spread the disease and expand its scope further. As time is required for a biological attack to develop, it can be used as a destructive weapon with its spread.

Early warning, detection and identification of biological weapon attacks, are main biological defense components helping to lighten the consequences.

The main step for detection of a biological threat is "Potential hazard" warning. As a consequence of the warning, samples are collected and the hazard is identified. Identification system can be presented as automatic and manual integrated to air measurement device. After the warning of a potential threat, system sends the measured air in liquid form to test kit without exterminating the biological threat within it and biological agent is detected from the kit.

- Bacteria – Virus – Mould – Fungus biological particle detection and warning is ensured.
- It has Automatic and Semi-automatic instant sample collection and storage unit.
- It stands by 365 days and there is no need for intermediate loading.
- There is automatic instant detection system for 8 different biological agents.

Charbon (anthrax), plague, ricin (toxic biological agent), botulinum(paralysis), enterotoxin type B(stomach disease), brucella (animal disease, stomach disease), Tularaemia (rodent disease), orthopox (smallpox disease).

AFSS BioReader system offers automatic or manual options.

- AFSS BioReader-Manual Sampling Mode: Sampling is performed with the help of buffer solution cotton and tube, and the personnel should wear special outfit or take samples behind biological cabin so as not to be exposed to biological agent.
- AFSS BioReader-Auto Sampling Mode: On automatic mode of the device, the device compounds the sample it takes from the air or from the liquid by straw with buffer solution automatically within the closed tank, drips it on the strip itself, makes the measurement itself and completely decontaminates the strip and the tank itself after the measurement and prepares them for next measurement.

After the sample is collected, strips are loaded to the device and automatic lock mode of the device is activated and it is locked for 60 seconds, it records strip result value to memory with the camera and the results obtained at the strip are logged into the device by using image processing technology and IR-UV lighting features. ID number of the person using the device and real-time GPS location of the device are automatically recorded into the device.

Biological Detection System can log all biological and chemical and radioactive test measurement strips and papers and visual detectors, record measurement values in the sector.



### OPTIONS

• AR-Z-47756	GPS Coordinate System
• AR-Z-74844	Automatic Liquid Sampling and Cleaning System
• AR-Z-42822	Automatic Air Sampling and Cleaning System
• AR-Z-43747	User Authorization and Identification System (ID System)
• AR-Z-22827	System of Operation Up to 1 Hour with Changeable Battery

### MATERIAL ORDER CODES

• AR-Z-1167	Manual Measurement System
• AR-Z-1276	Automatic Liquid Module
• AR-Z-1246	Automatic Air Module

### ADDITIONAL ACCESSORY MATERIAL ORDER CODES

• AR-Z-2346	Electrical Air Sampling Kit
-------------	-----------------------------

### CONSUMABLES MATERIAL ORDER CODES

• AR-Z-31755	Manual Liquid and Solid Sampling Kit
• AR-Z-31445	Manual Air Sampling Kit
• AR-Z-3271	Buffer Solution
• AR-Z-3228	Biological Waste Bag

### MEASUREMENT KITS

• AR-Z-4528	5 pack Biological DiagnosisKit
• AR-Z-4828	8 pack Biological DiagnosisKit
• AR-Z-41028	Buffer Solution
• AR-Z-3228	10 pack Biological Diagnosis Kit

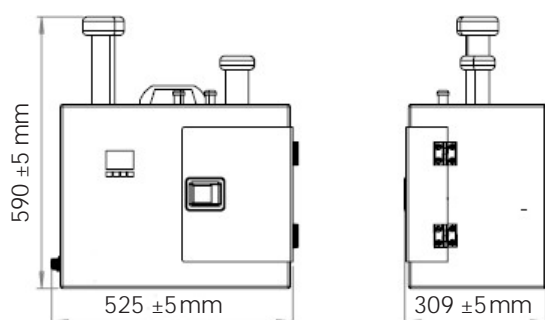



# AIR MEASURING DEVICE

AFSS Biological Detection System measures particles with a diameter between 0,3 and 10 m by using laser-based particle sensor. An LCD display, ensures settled visualization of PM1, PM2.5, PM4 and PM10 values. Detailed analysis of PM readings enables real-time particle size visualization. It measures the light radiated by separate particles carried within a sample air-flow by a laser beam. These measurements are used to determine particle size and concentration of the number of particles. Particle mass loads PM1 PM2.5 PM4 or PM10, are calculated from particle size spectrums and concentration data by assuming a particle concentration and refraction index (RI).

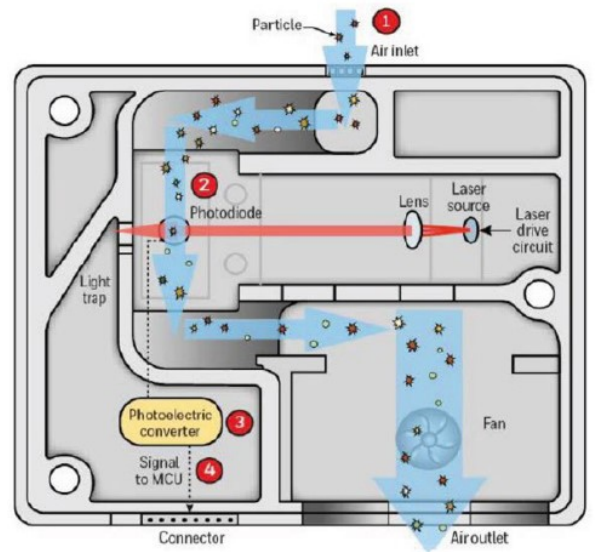
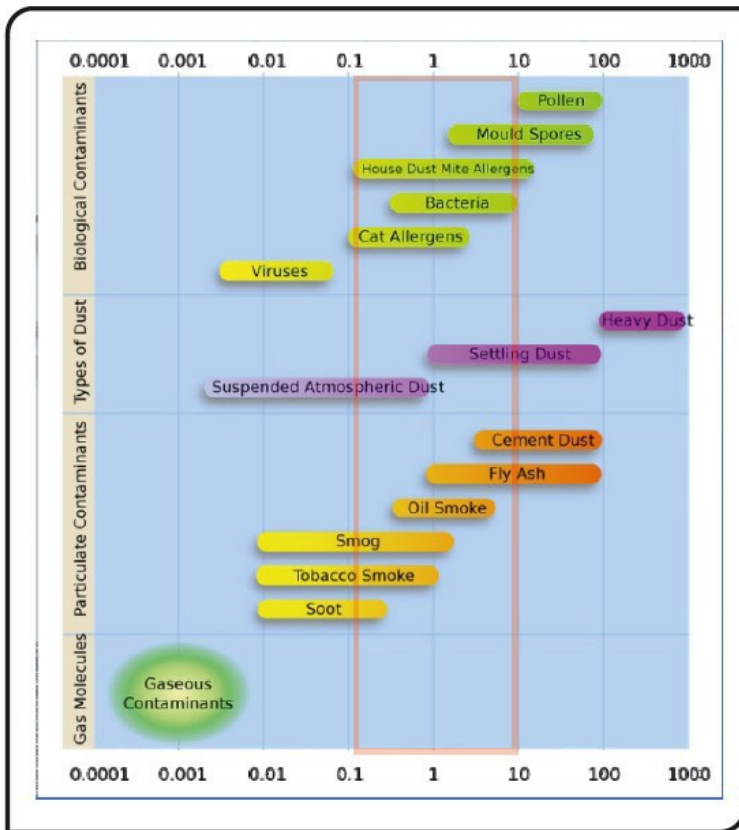

SnailFan



Sensor

This diagram shows types of atmospheric particulate matter and size distribution in micrometer (SNAIL FAN µm).

SPECIFICATIONS	CONDITION	VALUE	UNIT
Mass Concentration Range	-	0 - 1000	$\mu\text{g}/\text{m}^3$
Mass Concentration Size Range	PM1.0	0.3 - 10	$\mu\text{m}$
	PM2.5	0.3 - 2.5	$\mu\text{m}$
	PM4	0.3 - 4	$\mu\text{m}$
	PM10	0.3 - 10	$\mu\text{m}$
Mass Concentration Sensitivity PM1 and PM2.5	0 - 100 $\mu\text{g}/\text{m}^3$	$\pm 10$	$\mu\text{g}/\text{m}^3$
	100 - 1000 $\mu\text{g}/\text{m}^3$	$\pm 10$	%
Mass Concentration Sensitivity PM4 and PM10	0 - 100 $\mu\text{g}/\text{m}^3$	$\pm 25$	$\mu\text{g}/\text{m}^3$
	0 - 1000	$\mu\text{g}/\text{m}^3 \pm 25$	%
Annual Sensitivity Loss	0 - 100 $\mu\text{g}/\text{m}^3$	$\pm 1,25$	$\mu\text{g}/\text{m}^3 / \text{year}$
	100 - 1000 $\mu\text{g}/\text{m}^3$	$\pm 1,25$	% / year
Sampling Duration	-	$1 \pm 0.04$	second
Operating Voltage		24	VDC
Current Value Max.		2	A
Operating Temperature		-32, +49	$^{\circ}\text{C}$
Operating Humidity Range		0-96 %RH	%RH
Dimensions	Width x length x height	212x235x264	mm
Weight		5	kg

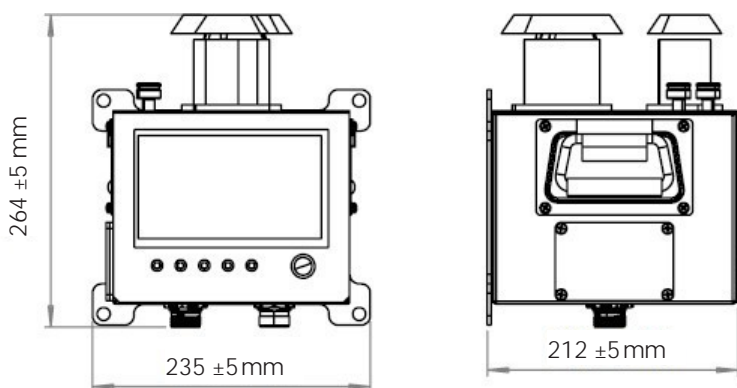



# CHEMICAL DETECTION DEVICE

Optical spectroscopy, is a very powerful technic for toxic gas analysis. It enables measurements of light absorption, emission, scattering and rotation, significant structural data and chemical definition of these. Each element of an optical filter series transmits the filtered light to the matching element of a photodetector series. It uses a Fourier transform infrared microscope (FTIR) to record the optical power transmitted from each filter.

This data is transferred to an RLS algorithm estimating incident spectrum with transfer spectrums of this filter and reconfigures transfer spectrum and infrared light source spectrum of our FTIR. An algorithm is used for matching the spectrums recorded in the library, including common chemical war agents and toxic industrial chemicals. TICs (Toxic Industrial Chemicals) detector is designed to give alarm in cases of detection automatic control of NH<sub>3</sub>, AsH<sub>3</sub>, CS<sub>2</sub>, HCN, HNO<sub>3</sub>, HCN<sub>2</sub>, PCI<sub>3</sub> and SO<sub>2</sub> amongst Toxic Industrial Substances and in case threshold values of hazardous substance concentrations are exceeded. CWA (Chemical War Agents) detector is designed to automatically control nerve gases (GA, GB, GD, GF, VX) and blister gases (HD ve L) amongst Chemical War Substances and warn the user in case threshold values of chemical agent concentrations are exceeded

Chemical Detector also gives warning for VOC\*\*, VVOC\*, LEL, Oxygen, sulphuredioxide and phosphate Gases.

Explanation	Boiling Point Range	Specific Sample Agents
Very volatile organic compounds (VVOC*)	<0 and 50-100	Propane, Butane, Chloromethane etc.
Volatile organic compounds (VOC*)	50 - 100 and 240-260	Formaldehyde, Limonene, Toleun,

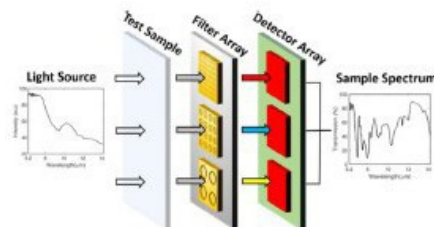
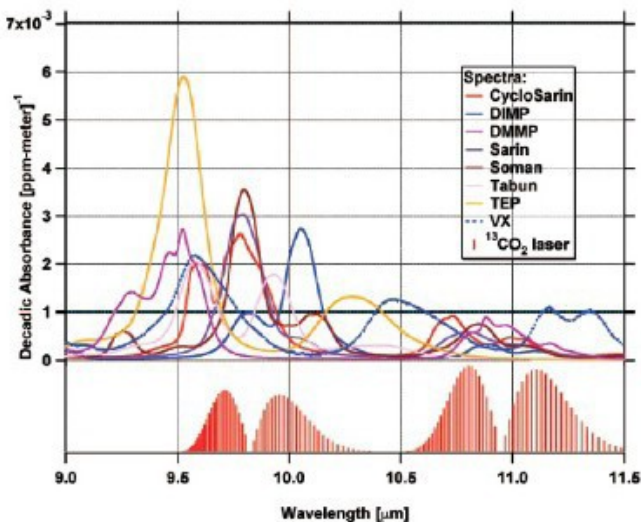

## Option 1

Abbreviation	Gas Group
AC	Blood Agent Gases (Hydrogen Cyanide, Cyanogen Chloride)
H	Blister Gases (Mustard, Lewisite)
CG	Choking Gases (Phosgene, Chloropicrin)
G	Nerve Gases (Sarin, Soman, Tabun, VX)

Alarm Level	Nerve Gases				Blister Gases	
	GA (mg/m3)	GB (mg/m3)	GD (mg/m3)	VX (mg/m3)	HD (mg/m3)	L (mg/m3)
1st Level	0,3	1	0,8	0,015	1	1
2nd Level	1	2,0	1,5	0,030	3	3
3rd Level	2	2,4	2,2	0,050	8	8
4th Level	4	2,6	3	0,070	10	10
5th Level	6	2,8	3,8	0,090	18	18
6th Level	8	3	5	0,100	35	35
7th Level	10	3,2	5,5	0,110	45	45

Specification	Value	Unit
Weight	12	kg
Dimensions (WidthxLengthxHeight)	332x450x645	mm
Operating Temperature	+15 - +65	°C
Power Requirement	24	VDC
	2	A
Communication	CAN J1939	RS485

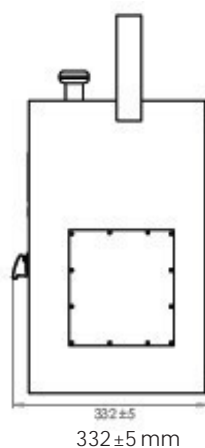
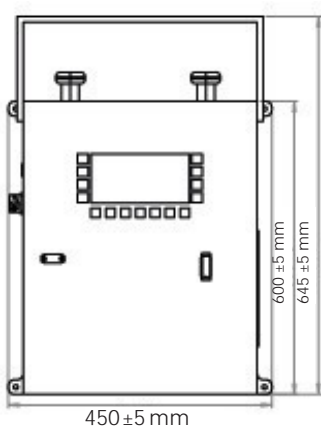

## Option2

#	Chemical	CAS #	Group	Phase*	PEL**** (OSHA)	REL*** (NIOSH)	IDHL*****
1	GA TABUN	77-81-6	1	Liquid	**	**	**
2	GB SARIN	107-44-8	1	Liquid	**	**	**
3	GD SOMAN	96-64-0	1	Liquid	**	**	**
4	GF CYCLOSARINE	329-99-7	1	Liquid	**	**	**
5	VX	50782-69-9	1	Liquid	**	**	**
6	CARBONYL SULFIDE	463-58-1	1	Gas	**	TLV- TWA 5 ppm	**
7	METHYL MERCAPTAN	74-93-1	1	Gas	C 10 ppm	0.5 ppm (1 mg/m <sup>3</sup> )	150 ppm
8	HD HARDAL GAS	505-60-2	2	Liquid	**	**	**
9	L LEVIZIT	541-25-3	2	Liquid	**	**	**
10	HL HARDAL LEVEZIT MIX	UN:2810	2	Liquid	**	**	**
11	BROMINE	7726-95-6	2	Liquid	TWA 0.1 ppm	TWA- 0.1ppm STEL- 0.3ppm	3 ppm
12	ACRYLONITRILE	107-13-1	2	Liquid	TWA 2 ppm C 10 ppm	Ca TWA 1 ppm C 10 ppm	85 ppm
13	ACETONE CYANOHYDRIN	75-86-5	2	Liquid	**	C 1 ppm	**
14	ETHYLENEIMINE	151-56-4	2	Liquid	**	**	100 ppm
15	CHLOROPICRIN PS	76-06-2	2	Liquid	TWA 0.1 ppm	TWA 0.1 ppm	2 ppm
16	AC HIDROJEN CYANIDE	74-90-8	3	Gas	**	**	**
17	SA ARSIN	7784-42-1	3	Gas	**	**	**
18	CK CYANOGEN CHLORIDE	506-77-4	3	Gas	**	**	**
19	CHLORINE	7782-50-5	3	Gas	TWA- 0.1 ppm	C- 0.5ppm	10 ppm
20	ETHYLENE OXIDE	75-21-8	3	Gas	TWA 1 ppm	TWA <0.1 ppm	800 ppm
21	FORMALDEHYDE	50-00-0	3	Gas	TWA 0. 75 ppm	TWA 0. 016 ppm	20 ppm
22	HYDROGEN CHLORIDE	7647-01-0	3	Gas	C 5 ppm	C 5 ppm	50 ppm
23	HYDROGEN FLUORIDE	7664-39-3	3	Gas	TWA 3 ppm	TWA 3 ppm	30 ppm
24	AMMONIA	7664-41-7	3	Gas	50 ppm	TWA 25 ppm	300 ppm
25	AC HYDROGEN CYANIDE	74-90-8	3	Gas	TWA 10 ppm	ST 4.7 ppm	50 ppm
26	HYDROGEN SULFIDE	10294-34-5	3	Gas	C 20 ppm; 50 ppm	C 10 ppm	100 ppm
27	NITRIC ACID	7697-37-2	3	Liquid	TWA 2 ppm	TWA 2 ppm, ST 4 ppm	25 ppm
28	CARBON DISULFIDE	75-15-0	3	Liquid	TWA 20 ppm C 30 ppm	TWA 1 ppm	500 ppm
29	SULPHUR DIOXIDE	7446-09-5	3	Gas	TWA 5 ppm	TWA 2 ppm, ST 5 ppm	100 ppm
30	ALLYLAMINE	107-11-9	3	Liquid	**	**	**
31	METHYL ISOCYANATE	624-83-9	3	Liquid	TWA 0. 02ppm	TWA 0. 02ppm	3 ppm
32	N-BUTYL ISOCYANATE	111-36-4	3	Liquid	**	**	**
33	NITROGEN OXIDE	10102-44-0	3	Gas	C 5 ppm	STEL 1 ppm	20 ppm
34	PHOSPHINE	7803-51-2	3	Gas	TWA 0.3 PPM	TWA 0.3 PPM - ST 1 PPM	50 PPM
35	CG FOSGEN-PHOSGENE	75-44-5	4	Gas	TWA 0.1 ppm	TWA 0.1 ppm	2 ppm
36	CX FOSGEN OKSIM	1794-86-1	5	Liquid	**	**	**
37	CHLOROSULFONIC ACID	7790-94-5	5	Liquid	**	**	**
38	DIMETHYLSUFATE	77-78-1	5	Liquid	TWA 1 ppm	TWA 0.1 ppm	7 ppm
39	METHANESULFONY CHLORIDE	124-63-0	5	Liquid	**	**	**
40	DIPHENYLMETHANE4*DIISOCYANATE	101-68-8	5	Liquid	P 0. 02ppm	TWA 0. 005 ppm- C 0. 020 ppm	75 mg/m <sup>3</sup>
41	ISOPROPYL ISOCYANATE	1795-48-8	5	Liquid	**	**	**
42	TERT-BUTYL ISOCYANATE	1609-86-5	5	Liquid	**	**	**
43	TETRAETHYL PYROPHOSPHATE	107-49-3	5	Liquid	TWA 0.05 mg/ m <sup>3</sup>	TWA 0.05 mg/ m <sup>3</sup>	5 mg/m <sup>3</sup>
44	TDI TOLUENE DIISOCYANATE	26471-62-5	5	Liquid	**	**	**
45	HN-1 NITROGEN IPERITBIS	538-07-8	6	Liquid	**	**	**
46	ED ETHYLDICLOARSIN	598-14-1	6	Liquid	**	**	**
47	1.2 DIMETHYLHYDRAZINE	540-73-8	6	Liquid	**	**	**
48	TERT-OCTYK MERCAPTAN	111-88-6	6	Liquid	**	**	**
49	ETHYL PHOSOHONOTHIONIC DICHLORIDE	993-43-1	6	Liquid	**	**	**
50	DP DIFOSGEN	503-38-8	7	Liquid	**	**	**
51	HN- 2 NITROGEN IPERIT	51-75-2	7	Liquid	**	**	**
52	HN- 3 NITROGEN IPERITTRIS	555-77-1	7	Liquid	**	**	**
53	PD PHENYLDICHLOROARCIN	696-28-6	7	Liquid	**	**	**
54	MD METHYLDICLOARSIN	593-89-5	7	Liquid	**	**	**
55	SULPHURIC ACID	7664-93-9	7	Liquid	TWA 1 mg/m <sup>3</sup>	TWA 1 mg/ m 3	15 mg/m <sup>3</sup>
56	PHOSPHORUS TRICHLORIDE	7719-12-02	7	Liquid	TWA 0.5 ppm	TWA 0.2 ppm	25 ppm
57	PHOSPHORUS PENTALLURIDE	7647-19-0	7	Gas	**	**	**
58	SULFURLY CHLORIDE	7791-25-5	7	Liquid	**	**	**
59	ALLYL ISOTHIOCYANATE	57-06-7	7	Liquid	**	**	**
60	ARSENIC TRICHLORIDE	7784-34-1	7	Liquid	TWA 0.010 mg/ m <sup>3</sup>	0.002 mg/m <sup>3</sup>	5 mg/m <sup>3</sup>
61	CYANOGEN	460-19-5	7	Gas	**	TWA 10 ppm	**
62	ETHYL PHOSPHONOUS DICHLORIDE	1498-40-4	7	Liquid	**	**	**
63	PARATHION	56-38-2	7	Liquid	TWA 0.1 mg/m <sup>3</sup>	TWA 0.2 mg/m <sup>3</sup>	10 mg/m <sup>3</sup>
64	PERCHLOROMETHYL MERCAPTAN	594-42-3	7	Liquid	TWA 0.1 ppm	TWA 0.1 ppm	10 ppm
65	SULFURLY FLOURIDE	2699-79-8	7	Gas	TWA 5 ppm	TWA 5 ppm - ST 10 ppm	200 ppm
66	METHLY HYDRAZINE	60-34-4	7	Liquid	C 0.2 ppm	C 0. 04ppm	20 ppm

* Phase state of the chemical at room temp.
** Data not given / Not in List / Value of Zero
*** NIOSH- REL recommended limit
**** OSHA- PEL allowable limit
***** IDHL Instant allowed limit



# RADIATION MEASURING DEVICE

AFSS detection system CBRN threats detections use both detection technology together in accordance with the conditions included in NATO AEP-54 standard. System is developed on radiation detection sensitivity on detectable radioactive particles. The system is developed on radiation detection sensitivity with regard to detectable radioactive particles. AFSS Radiation Probe is a gamma dose rate detector with IP66 protection which can be mounted to upper structure. This detector provides data output on communication and can be directly integrated to IT system of any vessel.

Radiation Probe can be used at various applications including marine/air/land and critical infrastructure systems. There are , 0-100 R/h low level and 100 mR/h-1000 R/h high level detections at radiation detection system.

• Steel Body	• Dimensions: 150x150x85 mm
• IP67 protection level	• Digital interface for connection: RS485-CANBUS
• The energy gap to be detected is at; 60keV - 3MeV range	

## ANALOG RADIATION MEASUREMENT UNIT

Analog Radiation Measurement Unit, is a radiation monitoring system which provides continuous and real-time radiation data about military vessels/vehicles. It provides detection and measurement.

It shows digital measuring results of the data received from the sensors on vessel/vehicle.

Analog radiation measurement unit consists of below components: Analog Radiation Control Panel; enables central indication and alarm for all remote radiation detectors.

A separate display module for each detector, shows gamma dose rate at detector location. This unit is also used in cases of training.

Remote radiological detectors continuously transmit data about radiation existence and level to control panel. Analog Radiation Measurement Unit can use 10 detectors, but different variations are also present in line with the requirements.

### Control Panel Specifications

- It continuously monitors dose rate and alarm status for each detector in use.
- It shows separate dose persistence times for each channel
- Predetermination of level for alarm
- Visual and voice warning at adjusted alarm level
- Lightening on panel
- Vibration resistant assembly wedges

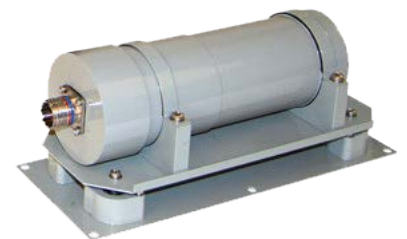

Absorption of gamma radiation (23 °C)

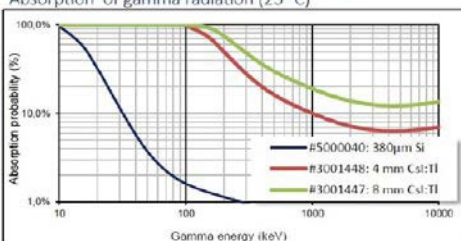

Absorption of gamma radiation (23 °C)

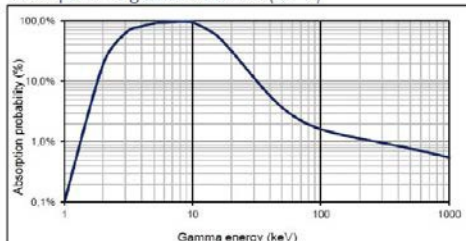

# CBRN SYSTEM OPERATION FLOW CHART

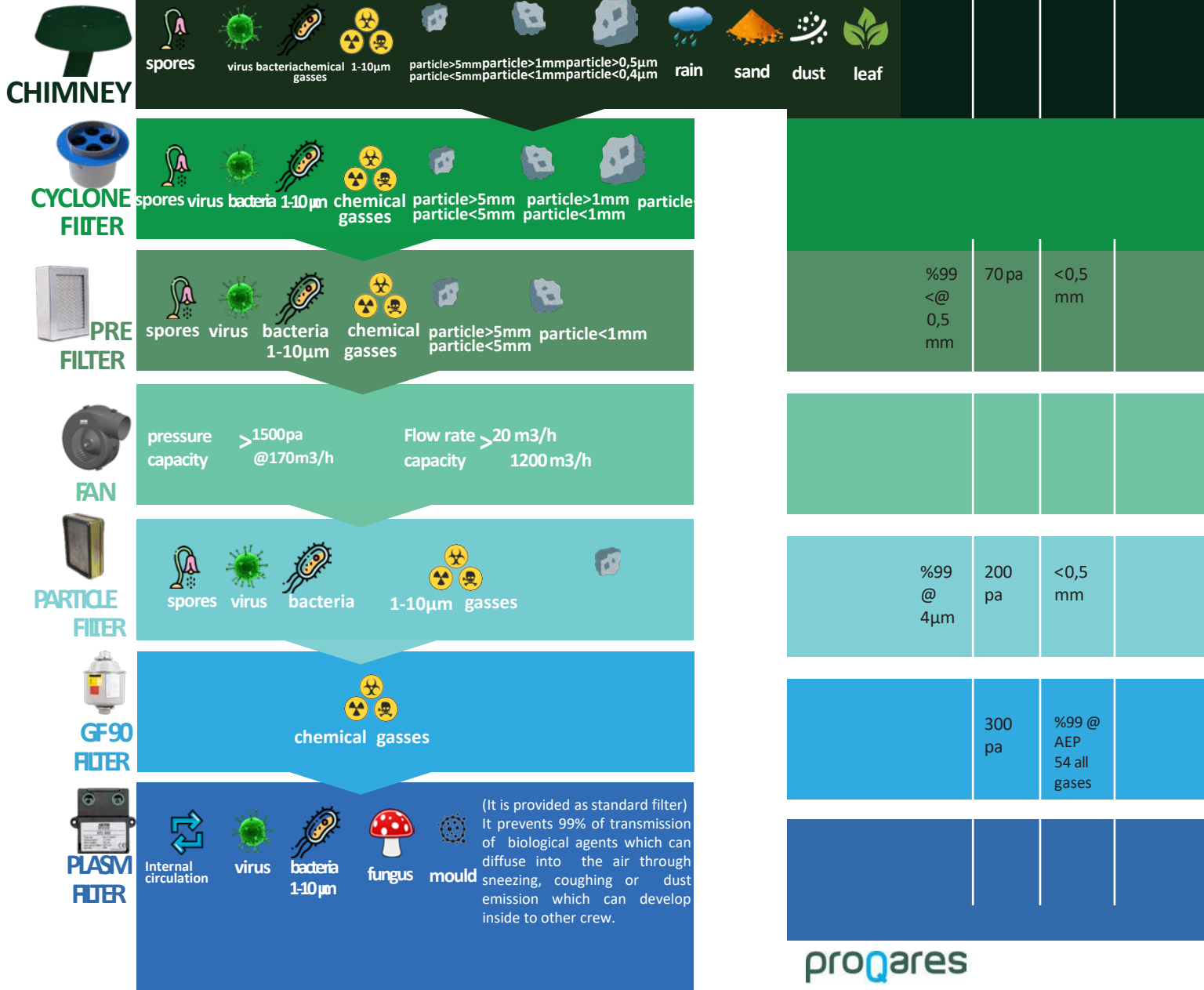

CBRN filters produced by AFSS have undergone testing by international institutions according to NATO AEP 54 standards, including exposure to real war agents, and have demonstrated success in these trials.

ARES FIRE SUPPRESSION SYSTEMS LLC.  
Attn. Mr. Varan  
9101 International Dr 1164 Orlando FL32819  
USA

Subject: COLPRO / AEP54, adsorption capacity experiments  
Your reference: AEP54  
Contact person: M. de Jonge

Dear Mr. Varan,

At the request of ARES FSS LLC (your reference AEP54) ProQares performed gas adsorption experiments on activated carbon according to the AEP-54 (Edition 2, October 2014) NATO Standard for colpro (collective protection) in a CBRN (chemical, biological, radiological and nuclear) environment. The aim of the investigation was to establish whether the carbon, when used in a colpro filter, will meet the stated requirements for the list of chemical warfare agents (CWA) and for the list of toxic industrial chemicals (TIC's). The details of the received samples are presented in Table 1. The sample was received September 2<sup>nd</sup> 2019, the experiments were performed between November 21<sup>st</sup> 2019 and February 19<sup>th</sup> 2020.

Table 1: Received samples

Sample code ProQares	Description by customer
19 PQA 1716	ARES FSS Activated Carbon 12*30 Mesh AR-CBRN-001

Lange Kleiweg 137  
P.O. Box 83  
2280 AB Rijswijk  
The Netherlands

[www.proqares.com](http://www.proqares.com)  
T +31 88 77 66900  
F +31 88 77 66999  
[info@proqares.com](mailto:info@proqares.com)

Date: 20-2-2020  
Page: 1 of 7

Ref.no.: 72168  
Doc.no.: 78746



# CBRN FILTER GENERAL SPECIFICATIONS

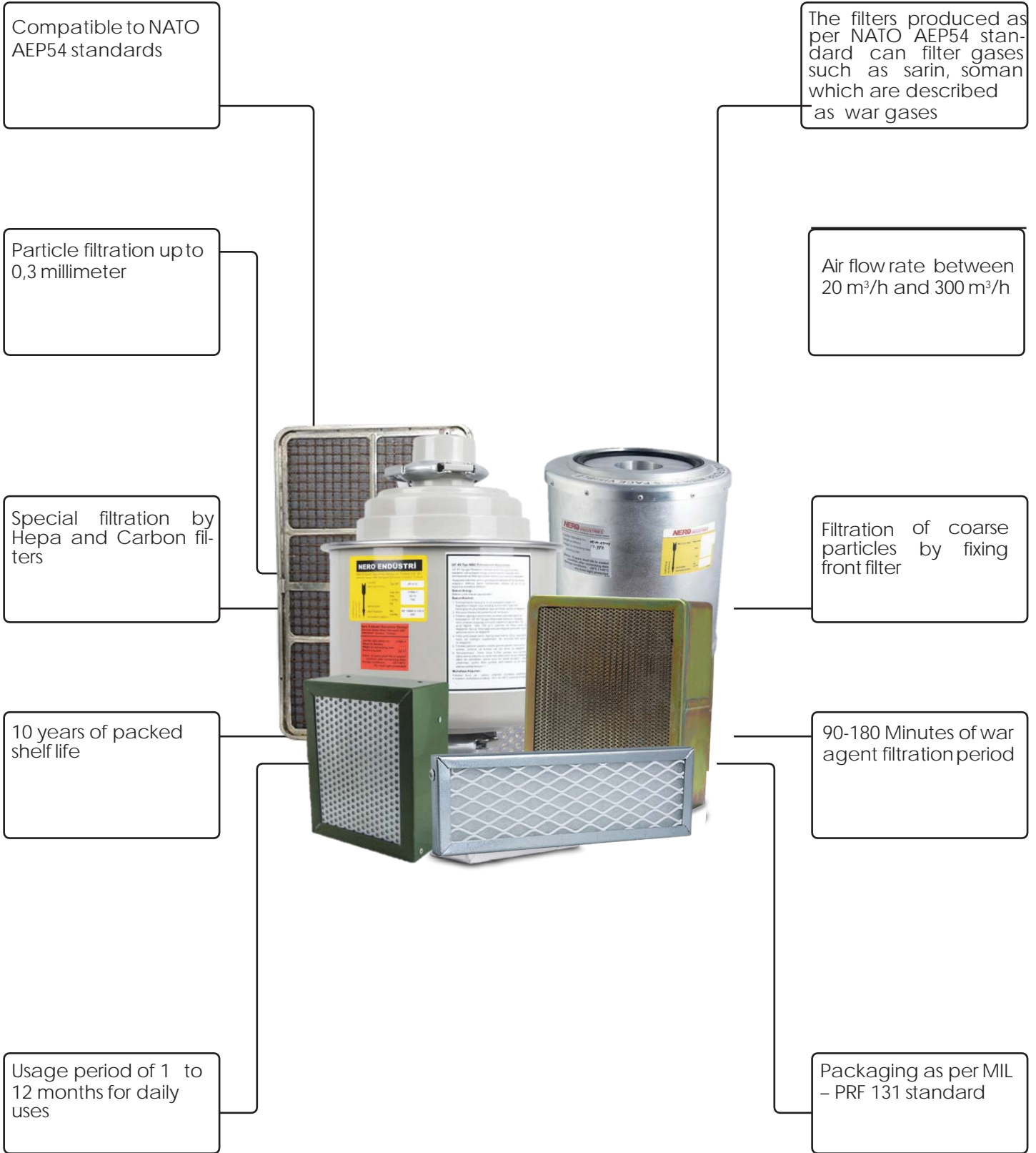



# GF-90 FILTER

Air Flow Rate  
90 m<sup>3</sup>/h

Storage Period  
10 Years / between 20-40 °C

Local Output %  
99.97 / 99.97

Weight  
23 lbs / 10,5 kgs(+0,5kg)

Dimensions (length x diameter)  
11,8" x 5,20"  
300 x 132 mm

NSN: 4240-27-062-0954  
TSK NSN: 4240-KK-020-9189



# CV-90 COMPATIBLE GAS FILTER

Air Flow Rate  
170 m<sup>3</sup>/h

Storage Period  
10 Years / between 20-40 °C

Local Output %  
99.97 / 99.97

Weight  
37 lbs / 17 kgs(+0,8kg)

Dimensions (length x diameter)  
12,8" x 14,52"  
325 x 369 mm

NSN: 4240-99-250-3437



# NATO TYPE 1 FILTER

Air Flow Rate  
170 m<sup>3</sup>/h

Storage Period  
10 Years / between 20-40 °C

Local Output %  
99.97 / 99.97

Weight  
11 lbs / 5 kgs(+0,8kg)

Dimensions (length x diameter)  
12,44" x 13,77"  
316 x 350 mm

NSN: 4240-99-176-1162

**STANDARDs**  
NATO AEP54

# CF-60 FILTER

 Air Flow Rate  
35 CFM / 60 m<sup>3</sup>/h

 Air Flow Resistance  
3 IWG / 750 Pa

 Local Outturn %  
99.97 / 99.97

 Weight  
11 lbs / 5.1 kg (±0.3 kg)

 Dimensions (width x length x diameter)  
9,05" x 14,45" x 4,10"  
230mm x 367mm x 104mm

NSN: 4240-12-147-4791  
NSN: 4240-27-052-4026



# GF-20 GAS FILTER

 Air Flow Rate  
20,4 m<sup>3</sup>/h

 Air Flow Resistance  
0,8 IWG / 200 Pa

 Local Outturn %  
99.97 / 99.97

 Weight  
3 lbs / 1,6 kg (±0,2 kg)

 Dimensions (width x length x diameter)  
5,54" x 6,96" x 2,95"  
138,5mm x 177mm x 75mm

NSN: 4240-01-365-0981 / 4240-00-203-3999  
NSN: 4240-27-068-4199



# HF-20 PARTICLE FILTER

 Air Flow Rate  
35 CFM / 60 m<sup>3</sup>/h

 Air Flow Resistance  
0,8 IWG / 200 Pa

 Local Outturn %  
99.97 / 99.97

 Weight  
1,59 lbs / 0,710 kg (±0,1 kg)

 Dimensions (width x length x diameter)  
5,54" x 6,96" x 2,31"  
138,5 X 177 X 58,8 mm

NSN: 4240-00-368-6291



## STANDARDS

NATO AEP54



## PRE FILTER

Air Flow Rate ---m <sup>3</sup> /h	Air Flow Resistance 0,81 IWG / 800 Pa	Local Outturn % 99.97 / 99.97
Weight 11 lbs / 0,9 kg (±0,1 kg)	Dimensions (widthxlengthxdiameter) 0,37" x 0,54" x 0,69" 9,5 mm x 13,8 mm x 17,6 mm	



## CYCLONE FILTER

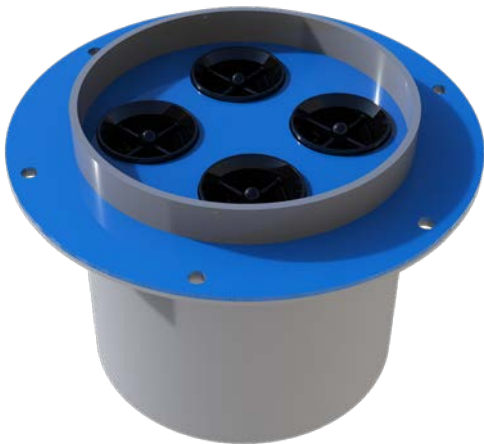

- On CBRN filtration system the dust particles within the drawn air are separated by giving "spin motion" (both circular and vertical motion) to airflow.
- When it is used before the filters, it extends the filter life.
- High capacities can be provided by parallel connection.

Cyclone filter separates the particles from the air by forcing the air with "spin method". The spinning air "pushes" solid particles to outer side of the air flow and provides the particles to fall outside the air flow and settle there. Cyclone collectors are generally used as separator for coarse dust from air flow and often as pre-cleaner before an efficient filter and/or a product separator.

The polluted air getting in from the entrance on upside of the cyclone with high speed, is forwarded to cyclone internal walls with centrifugal force of particles whose density is higher than the conveyer atmosphere, by giving it a helical flow form through cyclone construction.

Cyclones also reduces dust load reaching the filter by operating as first stage dust ejector before the filter on systems where dust load is high. By this means, it becomes possible to used filter unit more efficiently. These filters can be connected in series according to capacity calculations when it is necessary.



Filter Type	Filter Dimensions (diameterxsize)	Usage Type	Efficiency
Small Type	19mm x 66mm 0.75" x 2.6"	Single	92-96%
		Serial	95-99%
Wide Short Type	38mm x 102 mm 1.5" x 4"	Single	88-94%
		Serial	90-96%
Wide Long Type	38mm x 152 mm 1.5" x 6"	Single	92-95%
		Serial	96-98%

# CB-3 DIGITAL CONTROL UNIT

AFSS CBRN control unit with digital indicator, provides full control and monitoring opportunity by checking fan speed, filtration period and mechanism errors. It provides the most suitable air for the crew by automatically warming and cooling the air sending signals to air-conditioning systems.



## FEATURES



Communication	Canbus
Filter Pre-Counter	Available
Pressure Indicator	Digital
Buzzer	Available
Fan Speed Adjustment	3 Stages
Low Pressure Warning	Available
Fan Error Warning	Available
Manuel Test	Available
AEP54	Conformant
Warming Active Warning	Available
Air Conditioner On/Off Instruction	Available
No Filter Warning	Available
Change Filter Warning	Available
Built-In Test	Available
Dimout Function	Available
Weight	0,5 kg (±0,1 kg)





## CBRN GAS MASKS

Protective mask, together with a suitable filtration system or respiration system, protects user's face, eyes and respiratory organs; against gaseous, vapourish and solid or liquid aerosol chemical, biological, radiological and nuclear (CBRN) agents. Protective mask is produced in universal dimensions. The structure of sealing side, provides perfect sealing for all face shapes and sizes of adult population except for extremely small faces. Inhalation rooms for filter connection are equipped with Rd 40x1 / 7 '' screw thread as per EN 148-1 standard (NATO standard).

### ADVANTAGES

- All kinds of chemical, biological, radiological and nuclear agents, industrial toxic gases, riot control gases, etc.
- High user comfort
- Easy attach and removal
- Low breathing resistance
- Wide field of vision
- Protected visor against misting
- Corrective eyeglass application
- Easy decontamination and disinfection
- Easy liquid penetration (optional)
- Sweat drainage at exhalation chamber
- Compatibility with helmets and respiratory equipment
- High quality talk diaphragm, provides easy communication by using or not using communication devices.

### FEATURES

Average weight	560gr
Colour	Black
Effective field of vision	%77
Binoculars field of vision	%83
Filter connection thread	Rd 40x1/7"
Resistance against diffusion of NB agents	48 hours
Breathing resistance	
Breathing resistance at 30 lt/m	max. 25Pa
Breathing resistance at 95 lt/m	max. 80Pa
Exhalation resistance at 30 lt/m	max. 50Pa

# AR-WS40

## WEATHER STATION

The Weather Station, developed and manufactured by AFSS by domestic and national resources, is a device that measures the change of weather events. Thanks to its high-sensitive sensors, it measures the change of weather conditions with a minimum margin of error and transfers it to the user via communication interfaces such as RS-422 and CAN-BUS.

Weather Station can perform the measurements of:

- \*Temperature
- \*Relative humidity
- \*Wind speed
- \*Wind direction
- \*Atmospheric pressure

It is suitable for wheeled-tracked vehicles equipped with light and medium caliber weapons and command control shelters.

WindSpeed		Wind Direction	
Range	0–45 m/s	Azimuth	0–360°
Accuracy	± 0,5 m/s +%5	Accuracy	± 5°
Resolution	0.1 m/s	Resolution	0,1°
Response Time	< 1s	Response Time	<1s

Direction Of The SensorTo MagneticNorth		System General Specifications	
Azimuth	0–360°	Working Temperature	–40°C–+80°C
Accuracy	± 5°	Storage Temperature	–40°C–+85°C
Stability	0.30°	Input Voltage	18–32 VDC (MIL-STD-1275E)
Resolution	0,1°		

Relative Humidity		Dimensions	
Working Range	0-100%	Height	500 mm
Accuracy Tolerance	± 3 relative humidity	Diameter	85 mm
Response Time	1 sec	Base Diameter	138 mm
Resolution	%0,1	Weight	<5 kg

GPS Positioning		Air Temperature	
Latitude	90° N – 90° S	Range	–40°C–+125°C
Longitude	180° E – 180° W	Accuracy	± 0,25°C
Accuracy	0.01 m horizontally and vertically with RTK	Resolution	0,00625°C

Data Transmission	Can-Bus, RS - 422, RS-485, Ethernet
-------------------	-------------------------------------

Absolute Atmospheric Pressure	
Range	10–1300 hPa (mbar)
Accuracy	± 1,5 hPa (mbar)
Resolution	0,012 hPa (mbar)

### MILITARY STANDARDS

MIL-STD 810G MIL-STD 461F MIL-STD 1275E



## AR-MF 60 MASKED TYPE CBRN FILTRATION SYSTEM

AR-MF 60 Masked Type CBRN System designed and produced by AFSS engineers in accordance with MIL-STD-1472 requirements with an ergonomic structure as per standards such as NATO AEP-54, MIL-STD-810, MIL-STD-461.

Protection of the crew against chemical, biological, radiological and nuclear threats is provided by blowing adjustable fresh air filtrated by masks within the vehicle attached to private separate lines for each user with AR-MF 60 Masked Type CBRN System which has 60m<sup>3</sup>/h air flow rate. Gas and Particle filters in the system designed to be easily attached and removed, provides maximum speed during movement to hot zone.

### TECHNICAL SPECIFICATIONS

Air Flow Rate	60m <sup>3</sup> /h (35cfm)
Operation Temperature	-32°C — +49°C
Storage Temperature	-40°C — +63°C
Operation Voltage	28VDC
Current	Max. 7,5A @ 24VDC
Weight	~25kg
Dimensions	330 x 370 x 440 mm (En x Derinlik x Yükseklik)
Filters	''HEPA'' filter for particle filtration ''Activated carbon'' filter for gas filtration
Number of Crew To Be Protected	7 (optional)



# OVER PRESSURE CBRN SYSTEMS











## AROF-80 OVER PRESSURE FILTRATION SYSTEM



AROF-80 is a modular CBRN fan filter mechanism / air filtration system. AROF – 80 designed for mobile applications, includes cassette type filter group which has feature of quick filter change. With advanced technology digital user interface intervention to system, system warning control and error detection can be performed instantly. It can provide up to 80 m<sup>3</sup> /h (47 CFM) filtrated air within the area the personnel issituated.

### TECHNICAL SPECIFICATIONS

 It gives error when pressure difference is below the adjusted value.	 Storage Temperature -40°C / +71°C
 Dimensions: 49x90x28 cm	 Voltage Info: 32 VDC
 Shelf life: 10 years for each filter	 Adjustable Blast Valve
 Operation Temperature -32oC / +55oC	 Air Flow: 80m <sup>3</sup> /h (max)

# LASER WARNING SYSTEM

## GENERAL SPECIFICATIONS

» Laser Warning System (LWS) is designed for detection of laser radiation from laser assisted weapons and it can be used on any kinds of military vehicles.	» The system is protected against false alarms triggered by reflections, thunderbolt, gunshots and false alarms triggered by itself due to RF and electro-optical operations.
» LWS, detects, classifies and determines laser sources such as beam rider, target plotter, range finder, infrared lighteners.	» It provides detection of laser signals using impact, continuous wave and combination of these.
» LWS is an important component of defence skills of the vehicle. It includes visual warning, high detection possibility and low false alarm rate.	» The system manual, semi-automatic and automatic activation of all kinds of grenades that the vehicle could be equipped with according to the tactical requirements in security zone.
» When the high-speed processing and communication features are combined with electro-optical operation, it ensures correct and reliable operation.	» LWS system can detect laser radiation at wave length between 0,5 $\mu\text{m}$ and 1,6 $\mu\text{m}$ .

### LASER GUIDED WEAPONS THAT COULD BE DETECTED

- Kornet-EM Anti-Tank Missile lahat – Laser Homing Attack Missile
- UMTAS
- AGM-114R HELLFIRE II Romeo
- Spike-MR/LR/ER
- Javelin Missile
- HJ-12 (Red Arrow 12)
- BGM-71 TOW
- PARS 3LR
- Missile Moyenne Porte (MMP)
- MILANER
- NLAW (Next Generation Light)



# LASER WARNING SYSTEM OPERATION SCHEMATIC

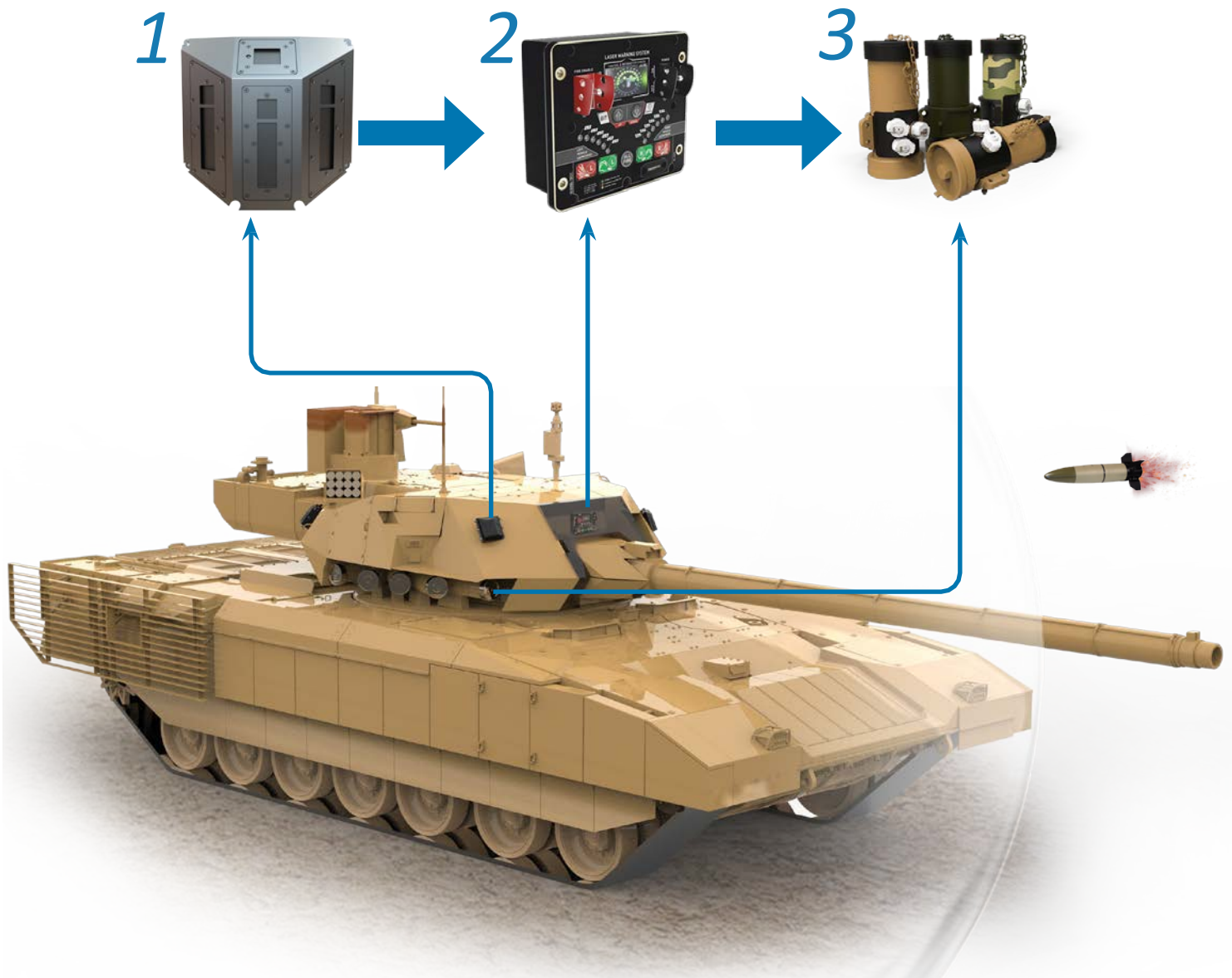

## 1

*Laser Warning Systems* with high detection capability developed by AFSS Industry, detect, classify and determine laser sources such as beam rider, target plotter, range finder, infrared lighteners. They are applied according to structure of the vehicle, ensure 360° detection and transmit the threat to control unit.

## 2

*Control Unit* analyses the threat transmitted by Laser Warning Sensor. It activates smoke grenade launcher system according to distance and location of the detected threat.

## 3

*Smoke Grenade Launcher System* ensures to create an efficient smoke screen at a battlefield with a range up to 45+5 depending on environmental conditions.

# LW4000 LASER WARNING SYSTEM

Laser warning systems are vital for detecting missile, UAV, and sniper threats, providing early alerts during covert or remote attacks. These systems enable timely defensive actions, reducing risks to personnel and equipment. Their affordability and precision have made them indispensable in modern defense, with many nations utilizing them to counter laser-guided weapons.

<b>Response Time</b>	Max. 500ms
<b>Threat Classification</b>	Laser Distance Meter (LDM) Laser Target Designator (LTD) Laser Guidance Beam (LGB)
<b>Detection Possibility</b>	LDM (Band I-II-III): %95 LTD (Band I-II-IV): %95 LGB (Band III-IV) : %99
<b>Detection Sensitivity</b>	10-20 (W/m <sup>2</sup> )
<b>Vertical Section Sight Range</b>	(-20 °) – (+ 70 °)
<b>Total Azimuth Visual Angle</b>	90° / Unit
<b>Communication System</b>	Canbus ( J-1939)
<b>Water and dust ingress protection</b>	IP67
<b>Operating Temperature</b>	-40°C / +60°C
<b>Storage Temperature</b>	-55°C / +85°C
<b>Salt Fog Resistance</b>	800 hours
<b>Power Consumption</b>	120 mA ±50 mA @24 VDC Nominal
<b>Weight</b>	1.8 ±0.5 kg



**Deployment:** Mountable on vehicles, personnel, and structures, these systems continuously monitor for laser markings.

**Early Warning:** Detecting laser markings or threats, the system alerts users and nearby personnel, offering a 10-30 second window to evacuate or reposition, minimizing casualties and damage.

**Anti-Laser Smoke Technology:** Developed by AFSS, this technology deploys smoke grenades to disrupt laser accuracy, reducing reflections by up to 96%.

**Precise Location Information:** With 15-degree sensitivity, the system enhances anti-drone, air defense, and radar efficacy, accurately locating ground threats for swift countermeasures.

**General Threats Addressed:** Snipers, Anti-Tank Missiles (ATGM), UAVs, Tanks, Vehicles with Automatic Weapon Stations, Grenade Launchers, Mortars

# LASER WARNING SYSTEM



LW2000



SGS-3



# LW2000 LASER WARNING SYSTEM

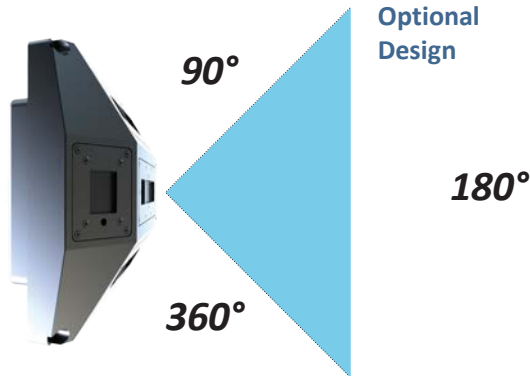

- Laser detectors detect, classify and determine 24 different Laser code and frequencies of laser-guided antitank threats within 50 milliseconds.
- It is safeguarded against false alarms such as sunlight, remote controller, artificial-fake light, hand laser as per NATO AEP 3733 standards. It has successfully passed high temperature, low temperature, high humidity, shock-vibration and EMI/EMC tests as per MIL STD 810H, MIL STD 461F and MIL STD 1275E standards.
- It determines threat identity and priority by comparing threat parameters with the threat data included in mission data folder which would be previously loaded to the system.
- This mission data folder can always be updated and the threat classes included can be increased.

TECHNICAL SPECIFICATIONS	
» Response Time	Max. 500ms
» Threat Classification	Laser Distance Meter (LDM) Laser Target Designator (LTD) Laser Guidance Beam (LGB)
» Detection Possibility	LDM (Band I-II-III): %95 LTD (Band I-II-IV): %95 LGB (Band III-IV): %99
» Detection Sensitivity	10-20 (W/m <sup>2</sup> )
» Vertical Section Sight Range	(-20 °) – (+ 70 °)
» Total Azimuth Visual Angle	90° / Unit
» Communication System	Canbus (J-1939)
» Water and dust ingress protection	IP67
» Operating Temperature	-40°C / +60°C
» Storage Temperature	-55°C / +85°C
» Salt Fog Resistance	800 hours
» Laser Detection Resolution	± 15°
» Power Consumption	120 mA ±50 mA @24VDC Nominal
» Weight	1.8 ±0.5 kg
» False Alarm	<0,2/hour

LASER BANDS		LDM	LTD	LGB
Band I	0.5 μm - 1.1 μm	+	+	
Band II	1.1 μm - 1.65 μm	+	+	
Band III	0.8 μm - 1.1 μm			+
Band IV	8-12 μm	+	+	+

INCIDENCE ANGLE MEASUREMENT SENSITIVITY		
Band I	Horizontal Axis	≤15° (rms)
	Vertical Axis	≤15° (rms)
Band III	Horizontal Axis	≤15° (rms)
	Vertical Axis	≤15° (rms)
Band III	Horizontal Axis	≤15° (rms)
	Vertical Axis	≤15° (rms)
Band IV	Horizontal Axis	≤25° (rms)
	Vertical Axis	≤25° (rms)

# AR-LDS 15 ARMORED VEHICLE APPLICATION

FULL PROTECTION  
**360°**

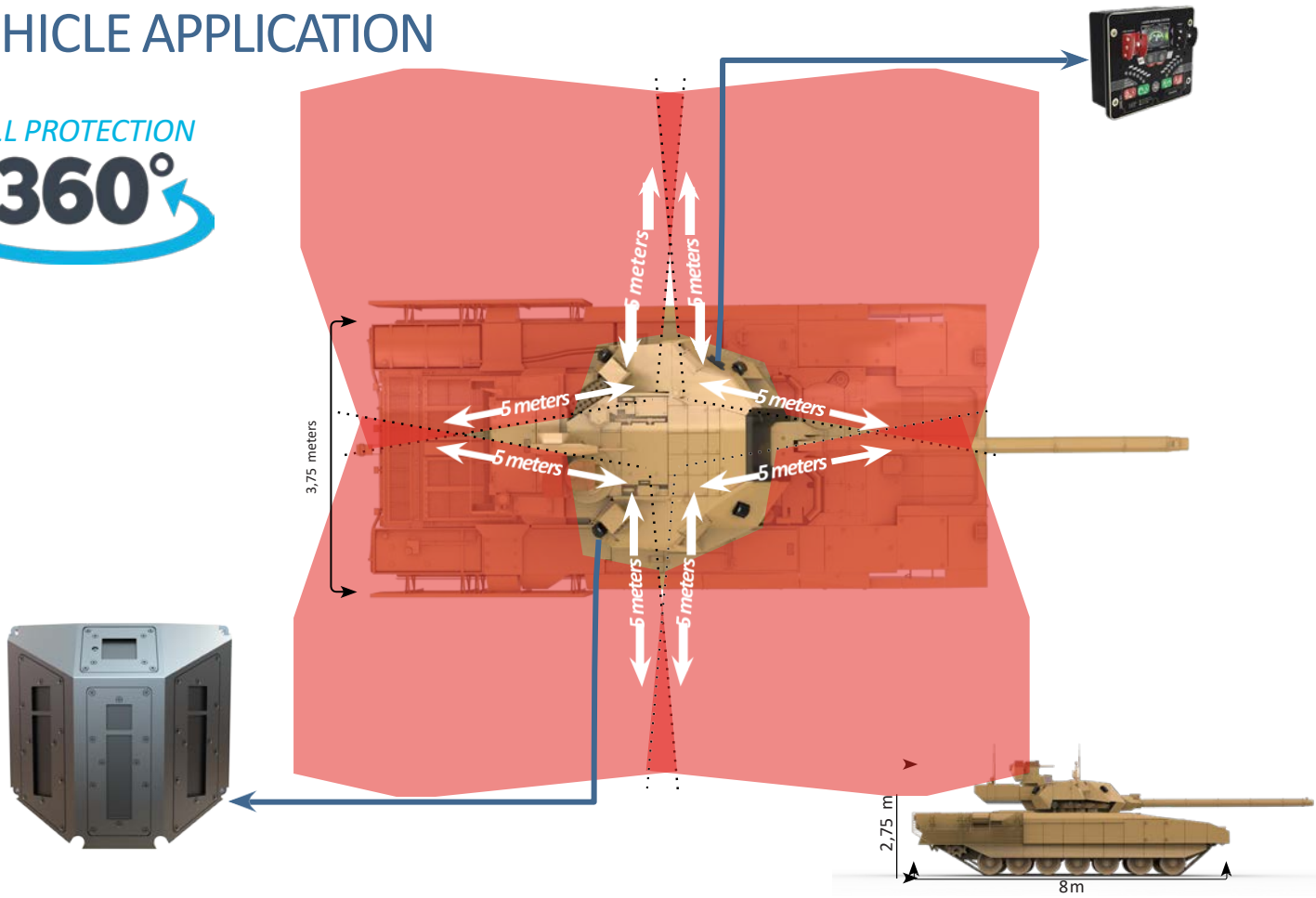

# AR-LDS 15 WARSHIP APPLICATION

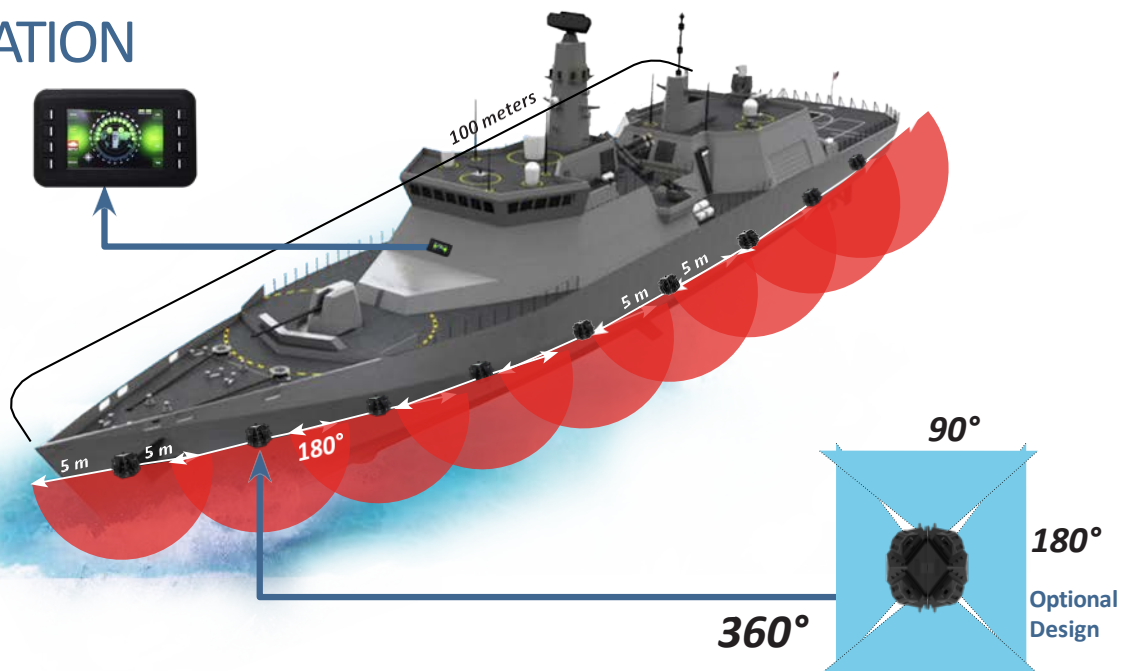



1675 S. Orange Blossom Trail Apopka, FL 32703 USA  
+1 (407) 614 7209 - sales@aresfss.com  
Please visit to our website for more information



# TWL-200 TACTICAL WEARABLE LASER WARNING SYSTEM





# TACTICAL WEARABLE LASER WARNING SYSTEM

- In an ever-evolving landscape of modern warfare and security challenges, the TWL200 Wearable Laser Warning System stands as a pinnacle of innovation, designed to ensure the safety and effectiveness of military personnel in laser-threat environments. This advanced system offers real-time laser detection, directional alerts, and a suite of cutting-edge features that empower users with unmatched situational awareness. In this document, we provide comprehensive details on the specifications and performance metrics that make the TWL-200 an indispensable asset for military operations.

## Power and Battery

- Power Source: Rechargeable built-in battery.
- Battery Weight: 140 grams(0.31 lb)
- Continuous Operation: Up to 24 hours.

## Field of View

- Horizontal Field of View: Up to 220°.
- Vertical Field of View: Up to 110°.
- Azimuth Detection: Up to 360°.

## Environmental Resilience

- Ingress Protection Rating: IP69K (Submersible).
- Drop Resistance: Up to 2 meters (6.56 feet).

## Audio and Vibration Modes

### Adjustable Volume Levels

- Low: 80 dBA
- Medium: 90 dBA
- High: 105 dBA

Mode Options: Sound mode, vibration mode, and sound and vibration modes together.

### Log Capability

- Log Storage: Up to 500 detections.

### Long Battery Life

Extended battery life allows for continuous operation without frequent recharging.

## Laser Detection

- Response Time: < 200 milliseconds.
- Wavelength Coverage: 700 to 1700 nanometers.
- Pulse Repetition Frequency (PRF) Detection: DC to 1 Mhz.
- Minimum Detectable Energy: 500 microwatts per square centimeter.

## Laser Types and Corresponding Wavelengths

Guidance Lasers: The TWL-200 can detect various guidance lasers used in military applications, including:

- 532 nanometers (green laser)
- 1064 nanometers
- 1300 nanometers
- 1550 nanometers

## Range-Finding Lasers

The system is capable of identifying range-finding lasers operating within the wavelength range of 700 to 1700 nanometers.

## Physical Dimensions

- Width: 58±2 mm(2.28 inches)
- Height: 44±2 mm (1.73 inches)
- Length: 97±2 mm (3.82 inches)
- Weight: 220 grams (0.49 lb)



# CCU-3 CONTROL UNIT



- **CCU-3 Control Unit** is a control unit which can automatically control laser and smoke grenade systems.
- It has capability of:
  - Detection
  - Classification
  - Transmitting incidence angle to the user on digital system
  - Keeping log record for laser warning system against laser threats as per NATO Stanag 3733 standards.
- CCU-3 Control Unit which can control Laser Warning system and laser grenade launcher system, has a structure that combines the leading edge and the most aesthetical specifications of its kind. It enables automatic and manual smoke grenade control.

## GENERAL SPECIFICATIONS

» Laser warning system control capability	» Power Consumption: 24 VDC nominal (16-32 V)
» Opportunity to control laser warning system and smoke grenade automatically and switch between systems	» Dimensions: 180x155x116 ±5 mm
» Capability to control up to 16 smoke grenades	» Weight: Control Unit: 1.9 ±0.3 kg
» Built-In Test Function (BIT)	» IP67 Water and Dust Ingress Protection
» Capability to detect and control two different types of smoke grenades	» Production as per IPC-A-610G Class 3 Standards PC
» Communication Interface: CAN-BUS /RS422 / RS232 Fast Ethernet	» MIL-STD-810G, MIL-STD-461, MIL-STD-1275E STANAG-3733
» Operating Temperature: -32°C / +49°C » Storage Temperature: -55°C / +85°C	» Capability to Communicate with Other Systems

## button SPECIFICATIONS

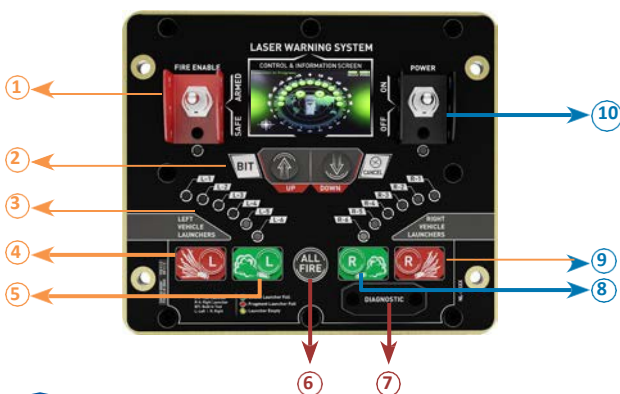

1.	SECURITY	6	ALL FIRE
2.	BIT	7	LOG
3.	LAUNCHERS STATUS	8	RIGHT SMOKE GRENADE IGNITION
4.	LEFT FRAGMENT IGNITION	9	RIGHT FRAGMENT IGNITION
5.	LEFT SMOKE GRENADE IGNITION	10	ON/OFF BUTTON

# GRENADE LAUNCHER SYSTEMS(66-76-80-81MM)

» It protects combat vehicles against visible and infrared observation, sensor-guided weapons, laser illuminators, radiators and laser-meters.

» It provides protection with location options including all angles between 50o and 360o with smoke grenade options produced suitable for structure of the vehicle.

» It enables an efficient camouflage screen in case of threat with distance range between 30 m – 150 m according to type of ammunition.

» Pyrotechnical and solenoid activation opportunity. Voice and visual warning for high voltage, high battery heat, low voltage, overcurrent errors.

» It can create instant, wide range and spectral sightline blockage besides dynamic smoke screens different from known smoke protection systems.

» It enables to control up to 16 smoke grenades manually and automatically by the help of control units to which system is integrated.

» It is tested for high temperature, low temperature, high humidity, shock-vibration and EMI/EMC as per MIL STD 810H, MIL STD 461F and MIL STD1275E standards.

» It enables to control different type and size smoke grenade systems manually and automatically with the option of 4 different control units.



# SLX GRENADE LAUNCHER

- It is developed with 100% local resources by AFSS.
- **SLX grenade launcher system** can be mounted to main vehicle externally.
- The ammunition type to be used on SLX system are **66-76-80 and 81 mm** smoke or fragmented grenade bullets.
- Smoke Grenade Launcher System ensures to create an efficient smoke screen camouflage action at a battlefield with a range up to 45+5 depending on environmental conditions.
- Dispersion time varies according to the ammunition used and optimum outturn is between 30-90 seconds.
- Capability of creating 90°, 180° and 360° smoke screen as per customer's choice.



## GENERAL SPECIFICATIONS

» 10 Years Shelf Life » Resistant against corrosion for 10 years	» Electrical Connection Connector: MS3476 WI 0-65 CANBUS (J1939) Connection Compliant
» Weight: 2.8 kg ± 0.5 kg	» MTBF Minimum 250,000 Hours
» Coating: Brass-Nickel coating	» Bracket options adjustable specially for vehicle
» Power Source: 28 VDC nominal (16-32)	» Moisture Resistance: %95
» Power Consumption: 120 mA ± 20 mA @28VDC	» Vibration and Shock Resistance
» Nominal Power Consumption: 6 A ± 2 A @28 VDC	» 800 Hours Resistance at Salt Test
» Electrical Resistance at Firing Position: 1-3.5ohm	» MIL-STD-461G, MIL-STD-810G, MIL-STD-1275E
» Electrical Connection: MS3470W10-6P	» Production as per IPC-A-610G Class 3 Standards

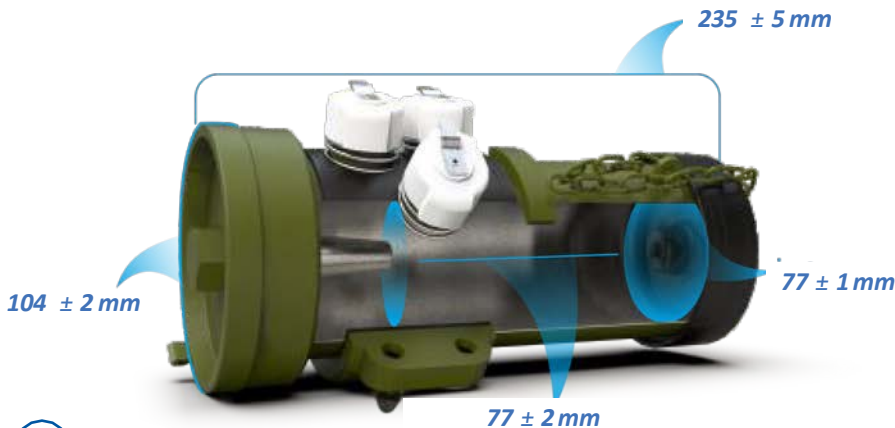

# System Operation Schematic

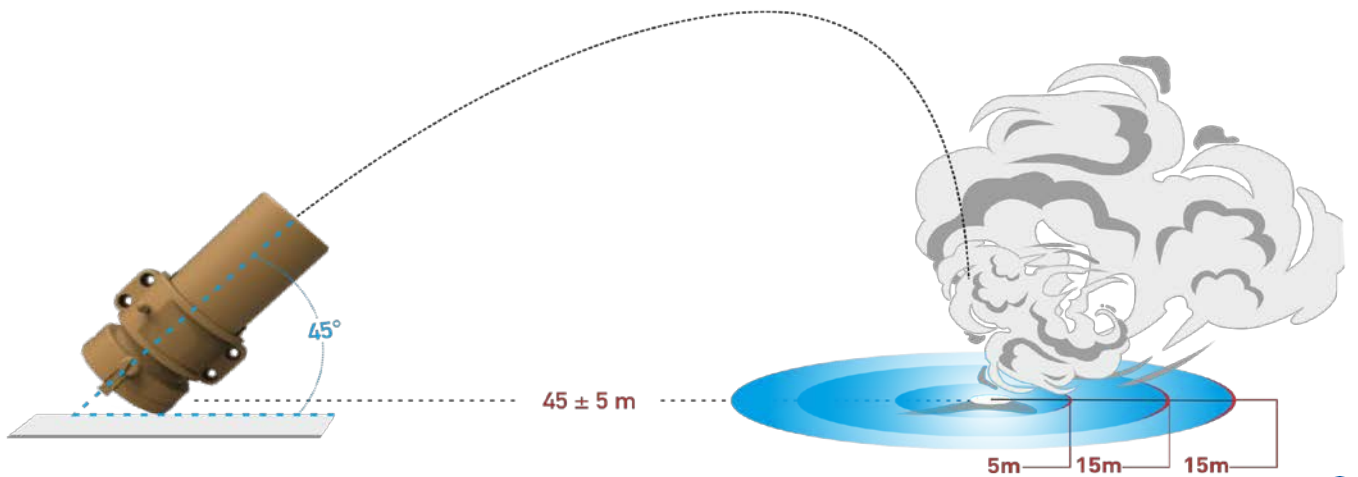
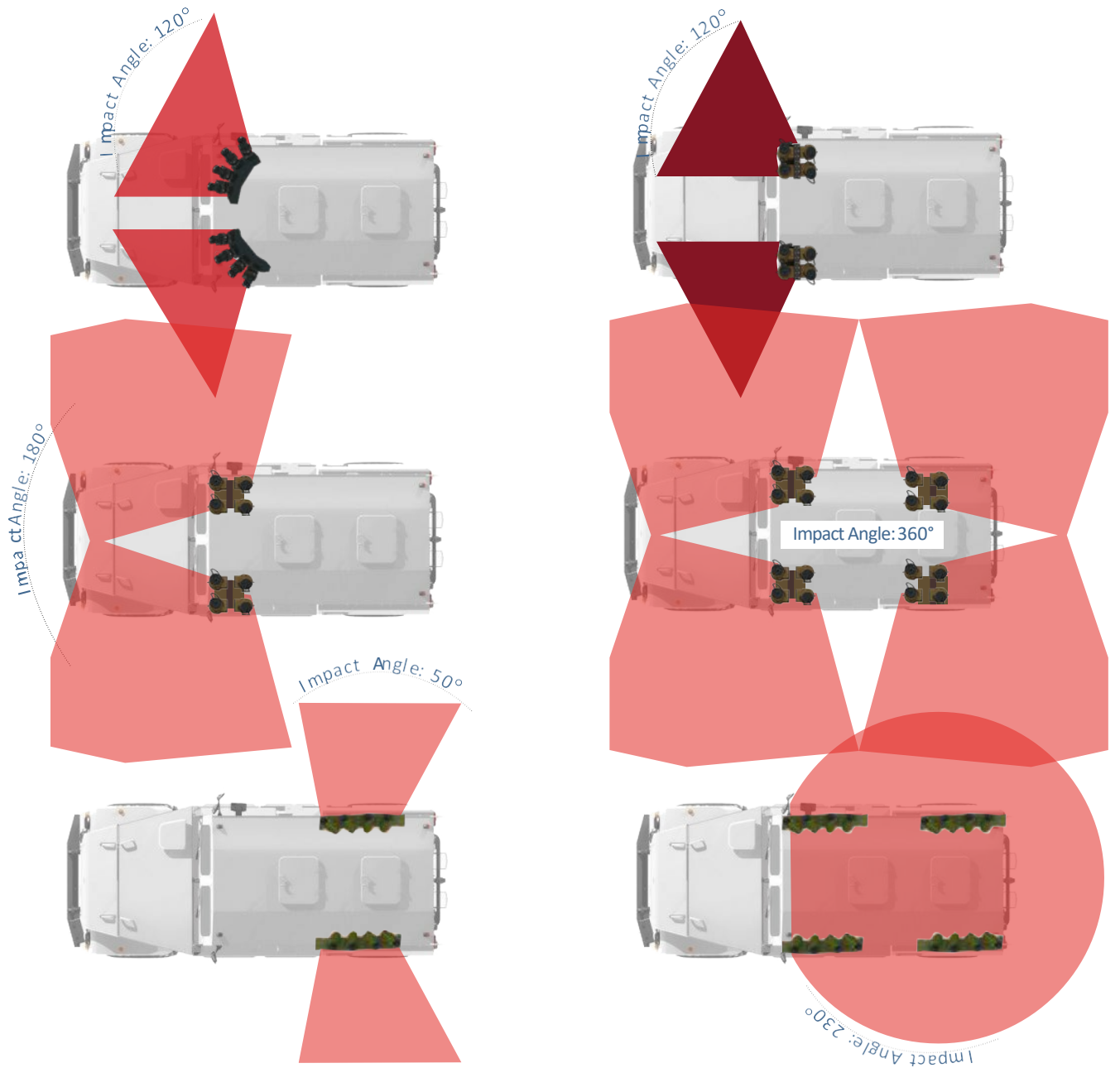

# LA-ML15 GRENADE LAUNCHER

- Fully Automatic Grenade Launcher for Suppression and Riot Control
- Type: Fully Automatic Grenade Launcher designed for suppression and riot control missions.
- Targeting System: Features optional color night vision and infrared (IR) movement detection to monitor and engage in low-visibility conditions.
- Non-Lethal Ammunition: Compatible with a range of non-lethal ammunition options, including standard tear gas, rubber bullets, and flashbangs, to safely disperse crowds and neutralize threats.
- Precision Targeting: Advanced targeting system allows for accurate delivery of non-lethal munitions, minimizing the risk to civilians and ensuring mission success.
- Automatic Fire Control: Automated firing capabilities facilitate rapid response in dynamic crowd control situations.
- Smoke Launcher System for Mission Support
- Operational Role: Provides tactical support for missions involving crowd management and riot control.
- Defensive Maneuver: Deploys smoke cartridges to create a visual barrier, enabling strategic retreats or advances without escalation.
- Cover for Forces: Offers concealment for maneuvering support forces into position during peacekeeping operations.
- Protection After Engagement: Used after non-lethal engagements to prevent targeting of security forces during repositioning.
- Asset Safety: Ensures the safety of valuable tactical vehicles during operations involving large gatherings.
- Command Vehicle Utility: Supports command post vehicles in maintaining operational control and safety during public order events.



**LA-ML15**  
Grenade Launcher with optional colored night vision

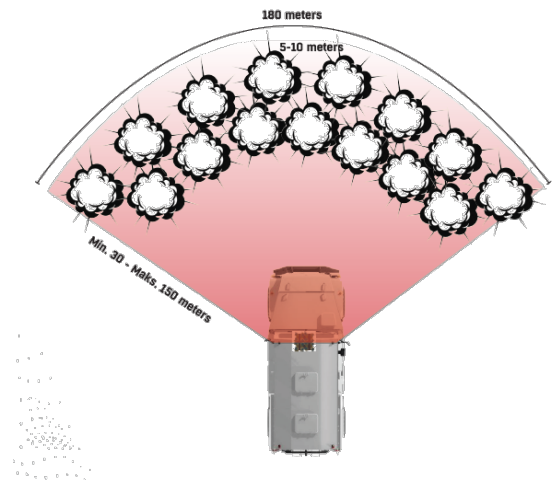

**Range is : ±45° Horizontal Angle**  
**0-45° Vertical Angle 10 meters to 150 meters range**

## GENERAL SPECIFICATIONS

• Specification	• Value	• Unit
• Operating Voltage	• 9-36 VDC	• V DC
• Firing Range	• Short (Low Velocity)	• 20-150 meters
	• Long (High Velocity)*	• 150-800 meters
• Ammunition Capacity	• 15	• Pieces
• Shooting Option	• Single Fire	• Pieces
	• Triple Fire	
	• All Fire	
• Operating Temperature	• -32 / +55	• °C
• Body	• Aluminum Anodized Body- 10 years corrosion warranty	
• Firing Pin / System Warranty	• 10.000 Times shooting / 2 Years	
• System Components	• Remote Controller, Launcher, Harness	
• Length	• 155 ±5	• Millimeters
• Height	• 380 ±5	• Millimeters
• Width	• 722 ±5	• Millimeters
• Barrel Length	• 200±5	• Millimeters
• Overall Weight(Max.)	• 30±2	• Kilograms
• Communication	• CANBUS J1939	
• MIL-SPEC Standards	• EMI/EMC : MIL-STD-461H	
	• EMI/EMC : MIL-STD-1275E	
	• Environmental : MIL-STD-810H	

# 40MM GRENADE TRILAUNCHER

The Ares Fire and Safety Systems 38-39 mm Tri-Launcher is a state-of-the-art smoke grenade launcher designed for military vehicles. This innovative system addresses the challenges associated with larger launchers (66 mm, 76 mm, 81 mm) by providing a reliable, easy-to-find, and sustainable alternative.

## Operational Advantages

- **Reliability:** Overcomes the quality and firing issues found in larger launchers.
- **Sustainability:** Easy access to ammunition ensures long-term operational viability.
- **User Control:** Advanced sensors provide real-time information on the status of each tube, enhancing situational awareness and control.
- **Ease of Integration:** Simplified mounting system reduces installation time and complexity.
- **Power Efficiency:** Low power consumption ensures minimal impact on vehicle power systems.
- **Compliance:** Adherence to MIL-STD-810G and MIL-STD-461G ensures performance in extreme conditions and environments.
- **Efficiency:** Quick reloading time of less than 30 seconds per unit minimizes operational downtime.

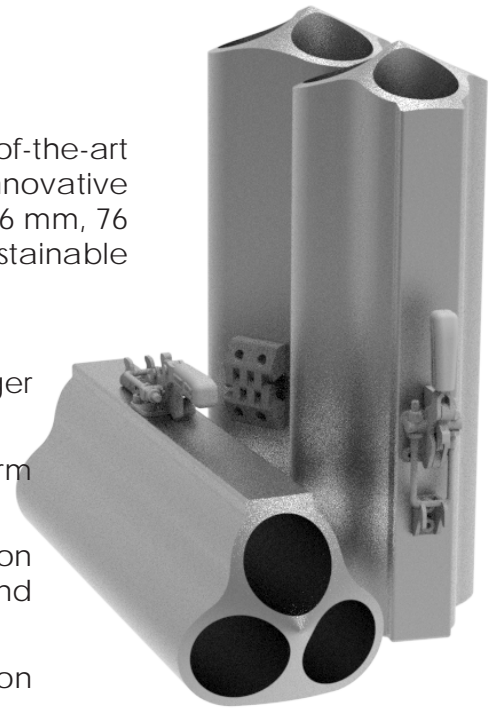

## GENERAL SPECIFICATIONS

» Caliber: 38-39 mm	» Durability: Capable of more than 5000 firings before maintenance is required
» Material: High-grade aluminum	» Corrosion Resistance: Up to 1000 hours
» Ammunition Types Supported: Over 12 different types	» Reloading Time: Less than 30 seconds per unit
» Sensor Technology: Full-empty sensors and microphone system for launch/misfire detection	» Standards: Compliant with MIL-STD-810G for environmental engineering and MIL-STD-461G for electromagnetic compatibility
» Mounting System: Specialized rail system with easy-to-locate brackets	» Power Requirements: 9-36VDC, 0.3 Amps during firing



# SELF PROTECTION POD for UAV



# SELF PROTECTION POD

Our company proudly presents the latest advancement in UAV self-protection technology—the MDAS (Multi-Defense Airborne System). This cutting-edge system is specifically designed to shield UAVs from kamikaze drones, missiles, and other guided threats using advanced defensive measures.

**Smoke Cloud Deployment:** The MDAS system can release a smoke cloud to obscure the UAV from enemy targeting systems.

**Black Coating Material:** A unique black coating powder is suspended in the air and attracted to any surface. This coating effectively blocks:

**Continuous Mission Capability:** Once the MDAS system is deployed, the UAV can continue its mission without interruption, effectively evading targeted attacks.

GENERAL SPECIFICATIONS	
» Thermal cameras (LWIR: 8-12 $\mu\text{m}$ , SWIR: 0.9-1.7 $\mu\text{m}$ , MWIR: 3-5 $\mu\text{m}$ )	» Activation Capacity: 4 firings per pod
» Thermal cameras (LWIR: 8-12 $\mu\text{m}$ , SWIR: 0.9-1.7 $\mu\text{m}$ , MWIR: 3-5 $\mu\text{m}$ )	» Reloading Time: Less than 30 seconds per unit
» Visual camera systems (400-700 nm)	» Standards: Compliant with MIL-STD-810G for environmental engineering and MIL-STD-461G for electromagnetic compatibility
» Voltage range of 9-36VDC and 0.5 Amps per pod to activate	» Machine learning, image recognition, and AI-based targeting systems

## MDASP – AREA OF SCREENING

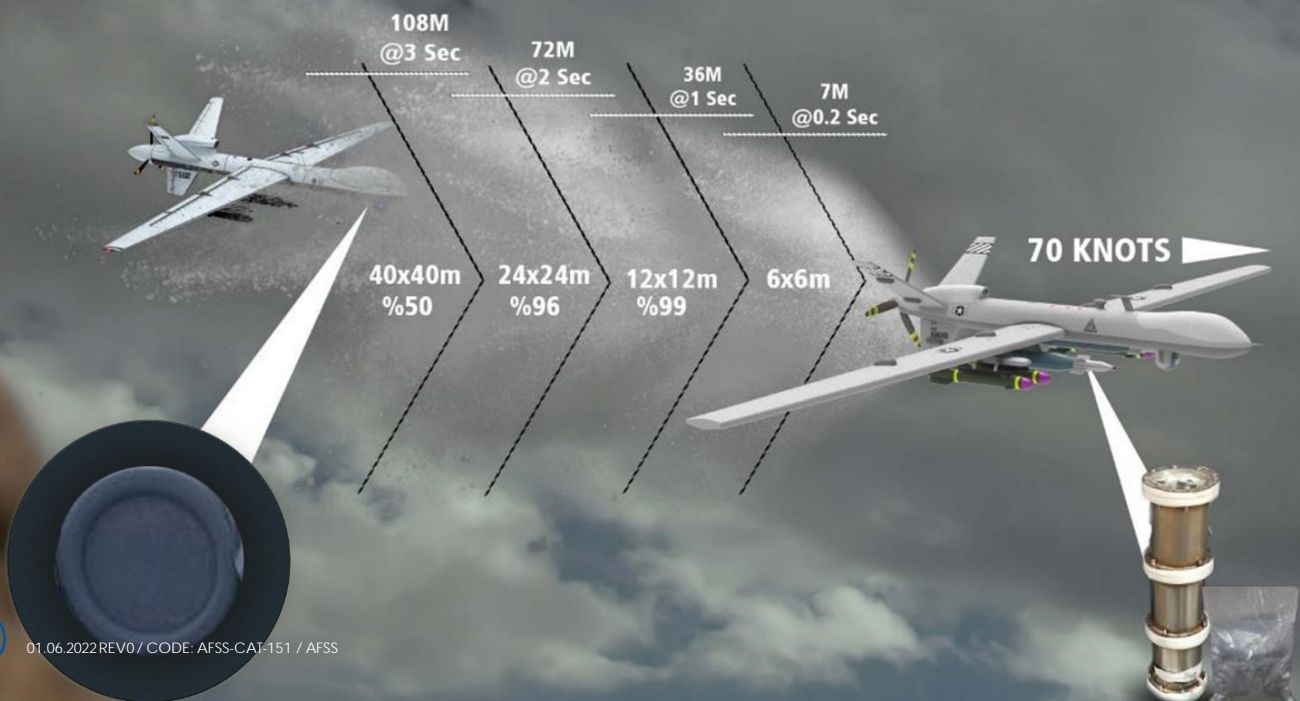

# CCU-6 CONTROL UNIT

- **CCU-6 Control Unit** which can control Laser Warning system and smoke grenade system has a structure that combines the leading edge and the most aesthetical specifications of its kind.
- Control unit with digital screen, provides easy use for the user by displaying on-vehicle schematic on the screen.
- It enables automatic and manual smoke grenade control. It can communicate with other systems.



## GENERAL SPECIFICATIONS

» Built-In Test Function (BIT)	» Dimensions: 180x155x116 ±5 mm
» Capability to control two different types of smoke grenades	» Weight: Control Unit: 1.9 ±0.3 kg
» Communication Interface: CAN-BUS /RS422 / RS232 Fast Ethernet	» IP67 Water and Dust Ingress Protection
» Operating Temperature: -32°C / +49°C	» Maximum 12 smoke grenade control
» Storage Temperature: -55°C / +85°C	» Production as per IPC-A-610G Class 3 Standards PC
» Power Consumption: 24 VDC nominal (16-32 V)	» MIL-STD-810G, MIL-STD-461, MIL-STD-1275E STANAG-3733

## BUTTON SPECIFICATIONS

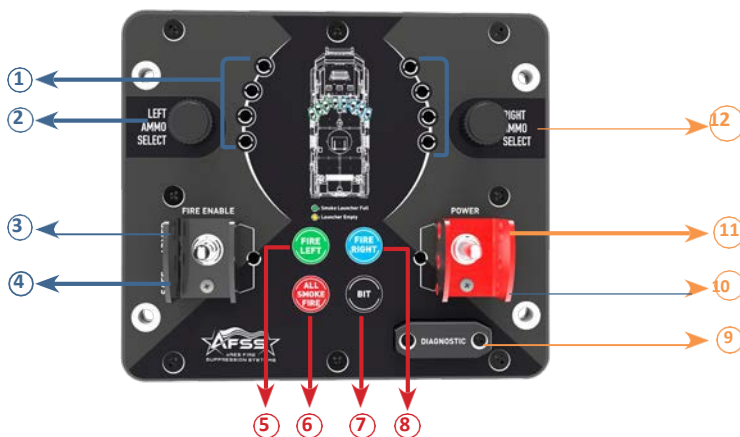

1.	LEFT LAUNCHER EMPTY/FULL LED: Shows the full/empty status of the Launcher.	7.	BIT: Build-in-test
2.	LEFT AMMOSELECT: Selects left ammo.	8.	FIRE RIGHT: Fires right launcher.
3.	FIRE ENABLE ARMED	9.	DIAGNOSTIC: Software download socket.
4.	FIRE ENABLE SAFE	10.	POWER OFF
5.	FIRE LEFT: Fires left launcher.	11.	POWER ON
6.	ALL SMOKE FIRE: Fires all launcher.	12.	RIGHT AMMOSELECT: Selects right ammo.

# MILITARY POWER SYSTEMS

All military vehicles and military platforms need extra power to keep their systems active, apart from the power produced by the vehicle. These powers are provided by a different power generating system or from the grid electricity at the location of the vehicle. Some platforms need such high power that they have to use all the power generating systems they have.

At the same time, there are dozens of systems on the vehicle, but the power generating systems are on average 4-5. There are power units in order for the systems to distribute and control these power needs automatically and to receive the errors and feedbacks that occur in the system and deliver them to the user via ethernet and remote connection. These power distribution units are systems that automatically distribute and control the power produced by the platforms on the vehicle as needed by the platform and systems. These smart power solutions are fully qualified systems that have passed the MIL-STD-810G, MIL-STD-461E tests and can operate in all harsh environmental conditions.

Customized design  
Supersilent 55 dB@ 7 meters

It can be designed  
and applied as Dual -  
Mobile - Platform

MIL-STD-1275E conformant  
MIL-STD-810G tests completed  
MIL-STD-461EMI tests completed





## MILITARY GENERATOR 3 kVA–RG3

### TECHNICAL SPECIFICATIONS



**GENERATOR TYPE**  
Mobile Generator



**STAND BY POWER**  
3 kVA



**CONTINUOUS POWER**  
2,5 kVA



**FREQUENCY**  
50 Hz



**COOLING SYSTEM**  
Water Cooling System



**VOLTAGE PHASE NUMBER**  
1



**CONNECTION TYPE**  
RS422 –TCP



**SOUND LEVEL**  
75 dB in 7 Meters



**WEIGHT**  
156 KG



**OPERATING TEMPERATURE**  
-32 / +55 °C



**STORAGE TEMPERATURE**  
-40 / +60 °C



**FUEL TYPE - CONSUMPTION**  
Diesel - 3LT/H



**BATTERY CAPABILITY**  
40 AH



**DIMENSIONS (L x W x H)**  
882×525×603 ±5 mm

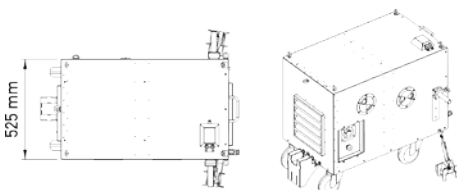
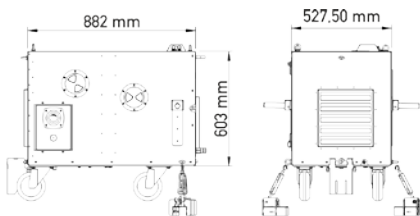

### ALTERNATOR SPECIFICATIONS

<b>OUTPUT POWER</b>	7 KVA
<b>PROTECTION CLASS</b>	IP23
<b>VOLTAGE SENSITIVITY</b>	± 2,5% V
<b>MAXIMUM SPEED</b>	3000RPM

#### military standards

<b>MIL-STD-461F</b>	<b>MIL-STD-810G</b>
<b>High Temperature</b>	<b>Low Temperature</b>
<b>Humidity Test</b>	<b>Vibration Test</b>

### ENGINE SPECIFICATIONS

<b>ENGINE</b>	Z482
<b>MODEL</b>	V1505T
<b>OUTPUT POWER</b>	9,3kW
<b>ENGINE TYPE</b>	Water Cooling Vertical Diesel Engine
<b>NUMBER OF CYLINDERS</b>	4
<b>MAXIMUM SPEED</b>	3000RPM
<b>STARTING SYSTEM</b>	Electrical Starting System



# MILITARY GENERATOR 28 kVA– RG28

## TECHNICAL SPECIFICATIONS



**GENERATOR TYPE**  
Platform/Ray



**VOLTAGE PHASE NUMBER**  
3



**STORAGE TEMPERATURE**  
-40 / +60°C



**STAND BY POWER**  
28,8 kVA



**CONNECTION TYPE**  
RS422 – RS485



**FUEL TYPE - CONSUMPTION**  
Diesel - 7,8LT/H



**CONTINUOUS POWER**  
22,5 kVA



**SOUND LEVEL**  
70 dB in 7 Meters



**BATTERY CAPABILITY**  
95 AH @24V



**FREQUENCY**  
50 Hz



**WEIGHT**  
1000 KG±5



**DIMENSIONS (L x W x H)**  
1195x800x1620±5 mm



**COOLING SYSTEM**  
Water Cooling System



**OPERATING TEMPERATURE**  
-32 / +55°C

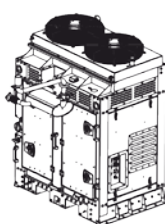
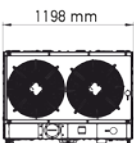
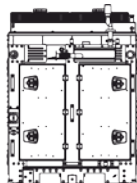
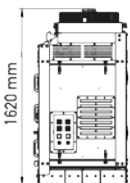

## ALTERNATOR SPECIFICATIONS

<b>OUTPUT POWER</b>	28,8KVA
<b>PROTECTION CLASS</b>	IP23
<b>VOLTAGE SENSITIVITY</b>	± 2,5% V
<b>MAXIMUM SPEED</b>	3000RPM

### military standards

<b>MIL-STD-461F</b>	<b>MIL-STD-810G</b>
<b>High Temperature</b>	<b>Low Temperature</b>
<b>Humidity Test</b>	<b>Vibration Test</b>

## ENGINE SPECIFICATIONS

<b>ENGINE</b>	Kubota
<b>MODEL</b>	V1505T
<b>OUTPUT POWER</b>	33 kW
<b>ENGINE TYPE</b>	Water Cooling Vertical Diesel Engine
<b>NUMBER OF CYLINDERS</b>	4
<b>MAXIMUM SPEED</b>	3000RPM
<b>STARTING SYSTEM</b>	Electrical Starting System

# MF-1005 GENERATOR CONTROL UNIT

(Single System)



- It shows existing error and health status of the generator.
- It has 95% BIT capability.
- It is positioned on the generator so that user can easily interfere in case of maintenance.
- It is designed as per IP67 Standards. It also provides the opportunity to reach last 500 detailed log thanks to diagnostic.
- It enables to operate in 9-36 volts range.
- The signals transferred only with connectors, there is no need for panel.
- It is conformant to MIL-STD-810G and MIL-STD-461E/F standards.

Dimensions (Width-lengthxheight)	140x213x160 ±5mm	Weight	3,1 kg±0.1	Communication Protocol	CANBUS J1939 -RS485 -RS422
-------------------------------------	------------------	--------	------------	------------------------	----------------------------

# AR-250 GENERATOR CONTROL UNIT

(Dual and Synchronized System)



- Easy switching between grid or multi-generator applications
- Connection of multiple generators in parallel with the existing grid together with the Intelicontroller 210 controller
- Two types of synchronization: Phase match or shift synchronization
- Isochronous (CAN) or Droop, load sharing including emergency drop
- Direct communication with EFI engines, including Tier 4 Final support

## Communication and connection capabilities

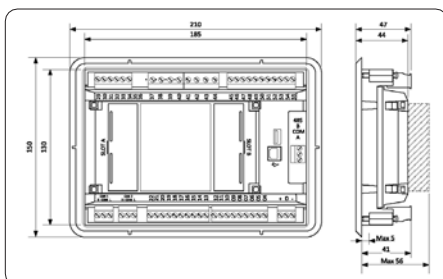

» USB, CAN and RS485
» USB master for configuration or firmware upload or download
» RS232 and additional RS485 with add-on module
» Internet access using Ethernet, GPRS/3G/4G with plug-in modules
» Configurable Modbus RTU or TCP and SNMP protocols v2 support
» Built-in PLC support with PLC editor and monitor including IntelliConfig
» Active SMS and emails in different languages
» Geofencing and monitoring via WebSupervisor

# AUXILIARY POWER UNIT (APU)

»APU (Auxiliary Power Units) systems are systems that provide energy for the active operation of the systems on the vehicle when the vehicle ignition is turned off, and provide the desired energy to the vehicle for air conditioning system.

»These systems, which are integrated into armoured vehicles, have the ability to provide power to carry out all activities on the vehicle without the vehicle engine running.

APU designs can be made between 2 kW and 100 kW according to customer's choice

It can actively operate weapon systems, vehicle computer, fire suppression systems, power distribution unit and CBRN systems on the vehicle, prolonging life of the engine and saving fuel.

It can be embedded into the military vehicle or mounted to outer shell.

It can cool inside of the vehicle without operating vehicle engine by adding hydraulic pump



It has capability to actively operate all the systems on the vehicle and perform all the activities.





## APU - K0803

### APU SPECIFICATIONS

 MAXIMUM AMPER  
300 A

 OUTPUT VOLTAGE  
28 VDC

 CONTINUOUS POWER  
18 kVA

 STORAGE TEMPERATURE  
-40 / +50 °C

 NOMİNAL ÇIKIŞ AKIMI  
22,5 kVA

 SOUND LEVEL  
80 dB in 7 Meters

 FUEL CAPABILITY  
External tank

 WEIGHT  
450 kg±5

 COOLING SYSTEM  
Water Cooling System

 OPERATING TEMPERATURE  
-32 / +55 °C

### GENERAL SPECIFICATIONS

 COMPRESSOR  
8 kW

 VOLTAGE  
28 VDC

 VOLTAGE SENSITIVITY  
28 ± 0,3

 FUEL TYPE / CAPABILITY  
Diesel / 6,3 Liter

 ENGINE TYPE  
Perkins

 DIMENSIONS (L x W x H)  
675x1754x947±5 mm



# APU - A0606T

## APU SPECIFICATIONS

 MAXIMUM AMPER  
240 A

 OUTPUT VOLTAGE  
28 VDC

 CONTINUOUS POWER  
11,6 kVA

 STORAGE TEMPERATURE  
-40 / +60°C

 NOMINAL OUTPUT POWER  
16 kVA

 SOUND LEVEL  
85 dB in 7 Meters

 FUEL CAPABILITY  
Diesel / External tank

 WEIGHT  
240 kg±5

 COOLING SYSTEM  
Water Cooling System

 OPERATING TEMPERATURE  
-32 / +49°C

## GENERAL SPECIFICATIONS

 COMPRESSOR  
Optional

 VOLTAGE  
28 VDC

 VOLTAGE SENSITIVITY  
28 ± 0,3

 FUEL TYPE / CAPABILITY  
Diesel / External tank

 ENGINE TYPE  
Horizontal

 DIMENSIONS (L x W x H)  
1420x623x420±5 mm

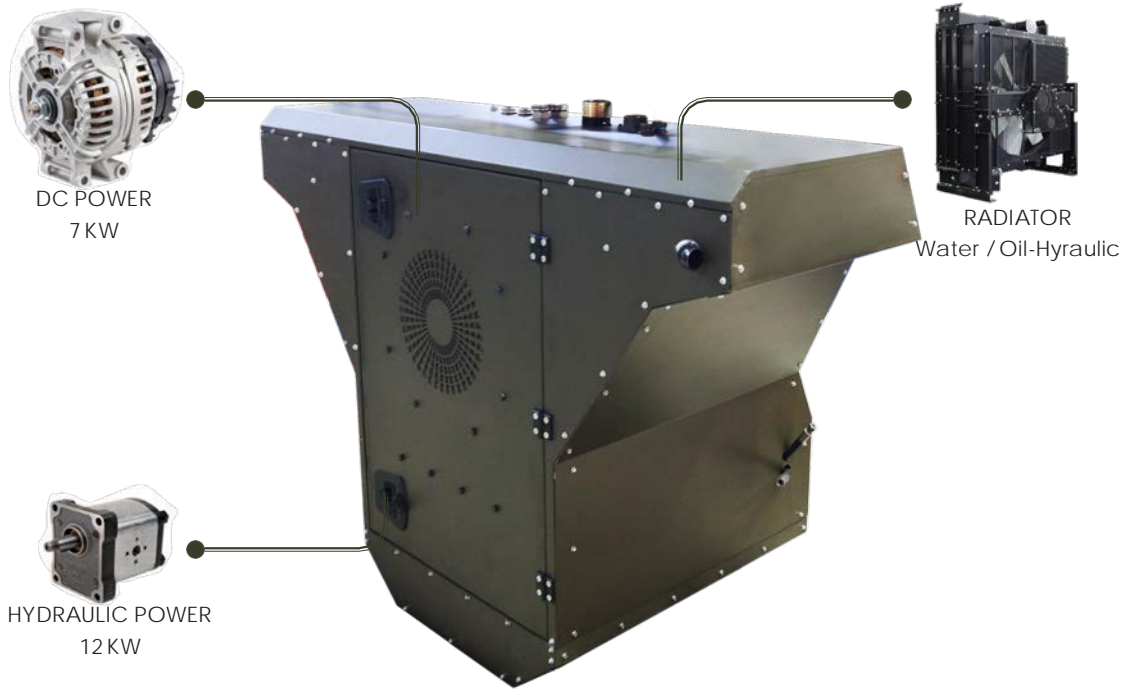

## APU - H1911K

### APU SPECIFICATIONS

 MAXIMUM AMPER  
160 A

 CONTINUOUS POWER  
20 kVA

 NOMINAL OUTPUT POWER  
33,3 kVA

 FUEL CAPABILITY  
External tank

 COOLING SYSTEM  
Water Cooling System

 OUTPUT VOLTAGE  
28 VDC

 STORAGE TEMPERATURE  
-40 / +55 °C

 SOUND LEVEL  
85 dB in 7 Meters

 WEIGHT  
450 kg ±5

 OPERATING TEMPERATURE  
-32 / +49 °C

### GENERAL SPECIFICATIONS

 COMPRESSOR  
Optional

 VOLTAGE  
28,5 VDC

 VOLTAGE SENSITIVITY  
28,5 ± 0,3

 FUEL TYPE / CAPABILITY  
Diesel / 8L

 ENGINE TYPE  
Kubota

 DIMENSIONS (L x W x H)  
1168x1595x860±5 mm

# MT-1310 APU CONTROL UNIT



- It is located near APU so that the user can intervene easily in case of maintenance.
- Existing errors on APU can be observed.
- There are buttons to directly intervene when there is a problem during automatic start of APU.
- It is designed as per IP67 Standards. Besides, it enables to reach last 500 detailed logs thanks to diagnostic.
- It is conformant to MIL-STD-810G and MIL-STD-461E/F standards.

## TECHNICAL SPECIFICATIONS

Dimensions (WidthxLengthxHeight)	140x213x160 ±5 mm
Weight	3,1 kg±0.1
Communication Protocol	CANBUS J1939
Operating Voltage	24 VDC

# F2022-CB REMOTE CONTROL UNIT



- It is used to remote control APU.
- Being located by vehicle driver, it enables to reach all the data on APU with the information screen on it.
- Control unit enables to activate-cancel APU system, to activate-cancel air conditioning system.
- It is designed as per IP67 Standards.
- It is conformant to MIL-STD-810G and MIL-STD-461E/F standards.

## TECHNICAL SPECIFICATIONS

Dimensions (WidthxLengthxHeight)	45x155x85 ±5 mm
Weight	0,48 kg ±0.1
Communication Protocol	CANBUS J1939
Operating Voltage	24 VDC

[aresfss.com](http://aresfss.com)

